



LAGIOIASTUCCHI
DECORAZIONI IN GESSO
■■■■■■■■



by
VITO LAGIOIA







Il gesso è un materiale naturale ed ecologico che grazie alla sua versatilità, praticità e resistenza si impone come uno dei materiali più usati nell'edilizia.

Negli anni '70 Vito Lagioia trasforma la propria passione in una nuova attività d'impresa. Fantasia, professionalità ed esperienza rendono ben presto l'azienda leader a livello regionale, in grado di realizzare qualsiasi opera si prospetti.

Negli anni '80 sono i figli a dare un'impronta manageriale all'azienda, facendola crescere ulteriormente anche a livello nazionale. Con la nascita di Lagioia Vito snc viene segnato un nuovo percorso, clienti e opere realizzate testimoniano l'alta specializzazione del personale e la capacità di far fronte a qualsiasi opera di restauro e di realizzazione su disegno e progetto.

Nel 2008, nell'era di Internet, L.V. Stucchi srl caratterizza la fusione delle nuove tecnologie con l'anima artigiana, la sapienza e l'esperienza di 30 anni di lavoro.

Oggi l'azienda produce, vende, installa e restaura stucchi decorativi in gesso, cemento e gessi speciali ideali anche per applicazioni all'esterno.

Plaster is a natural and ecological material. Thanks to its versatility, handiness, and resistance, it is one of the most used materials in its trade. During the 1970's Vito Lagioia transformed his passion into a working trade. Fantasy, professionalism, and experience helped the company become well known in the region. The company was able to do any type of work that it was asked to do.

In the 1980's, Vito Lagioia's sons gave a hand in expanding the company with managerial power thus helping the company's reputation become nationally known. With the birth of Lagioia Vito snc a new path is laid out for the company. Satisfied clients and jobs well finished have demonstrated the high quality work completed by our experienced employees. They also demonstrate our ability to bring forth any restoration job, designs, and projects.

In 2008, which is known as the internet era, L.V. Stucchi srl portrayed the fusion between new technologies and hand-crafted work with a 30 year background full of experience.

Today the company produces, sells, installs, and restores decorative plaster, cement, and special plasters for internal and external works as well.



Indice

Indice generale



GENERAL INDEX

Articolo	Pagina	Articolo	Pagina	Articolo	Pagina
Cornici lineari "C"	8 - 27	Fregi "F"	64 - 68	Boiserie "B"	130 - 131
Cornici fondi luce "C"	28 - 31	Cassettonati	71 - 72	Tozzetti "T"	132
Cornici lavorate "C"	32 - 45	Rosoni "R"	74 - 97	Applique "A"	134 - 138
Cornici mezza altezza "C"	46 - 55	Sovrapporta "SP"	100 - 104	Mensole "M"	140 - 142
Cornici da riquadro "C"	56 - 58	Caminetti "SC"	106 - 107	Lesene "L"	144 - 147
Cornici per spigoli "C"	59	Bassorilievi "B"	109 - 124	Colonne "C"	149 - 155
Angoli e spigoli	60 - 62	Pannelli "P"	126 - 128	Novità 2021	156

ARTICOLO	PAGINA	ARTICOLO	PAGINA	ARTICOLO	PAGINA	ARTICOLO	PAGINA	ARTICOLO	PAGINA	ARTICOLO	PAGINA
		101	18	130a	58	167	28	204	19	237	34
L10	146	102	19	131	59	167a	29	205	19	237D	44
L12	146	103	22	133	67	167s	29	206	48	238	34
13	141	104	22	134	67	168	28	207	48	238D	45
14	141	105	22	135	71	168a	29	208	48	239	10
15	141	106	25	136	71	168s	29	209	10	240	8
L16	146	107	27	137	71	169	136	210	9	241	101
L19	145	108	31	138	71	169a	136	211	12	242	101
21	141	109	32	139	71	171	9	212	10	243	101
L23	145	110	32	140	71	172	13	213	32	244	101
L27	144	111	33	141	71	175	13	214	14	245	101
L30	144	112	33	142	71	184	13	215	10	246	100
L34	144	113	43	143	72	185	13	216	14	247	100
70	55	114	43	144	87	186	19	217	14	250	104
71	55	115	43	145	93	187	18	218	14	251	104
72	55	116	43	145D	93	188	13	219	14	252	104
72A	55	117	47	146	93	189	18	220	12	253	104
73	55	118	47	146D	93	190	13	221	12	254	104
74	64	119	47	147	93	191	14	222	13	255	104
75	64	120	47	147D	93	192	48/57	223	11	256	104
78	132	121	47	148D	94	192a	57	224	28	257	104
79	65	122	47	149	97	193	48/57	224a	61	258	106
88	68	123	47/58	150	97	193a	57	224s	61	259	106
89	68	123a	58	151	97	194	57	225	11	260	107
90	46	124	47/58	152	97	194a	57	226	33	261D	109
90D	46	124a	58	153	97	194b	57	227	48	262	110
91	46	124c	58	154	97	195	48/57	228	34	262D	110
91D	46	125	47/57	154 (foto)	98	195a	57	229	12	263	110
92	46	125a	57	155	103	195b	57	230	15	263D	110
92D	46	126	47	156	103	197	48/57	231	9	264	126
93	46	127	49	157	103	197a	57	232	28	265	126
93D	46	128	49	158	103	201	10	233	15	266	127
96	43	129	50/58	159	103	202	19	234	59	267	127
97	43	129a	58	163	14	202a	62	234c	60	268	128
99	15	129b	58	164	14	202s	62	235	15	269	128
100	17	130	58	166	28	203	19	236	49	270	128

Indice

per articolo



ARTICLE INDEX

ARTICOLO	PAGINA	ARTICOLO	PAGINA	ARTICOLO	PAGINA	ARTICOLO	PAGINA	ARTICOLO	PAGINA	ARTICOLO	PAGINA
271	130	334	100	519	78	566	72	610a	56	662	68
272	138	335	100	520	78	567	72	611	56	663	87
273	138	336	136	521	79	568	134	611a	56	664	137
274	138	337	149	521D	94	569	134	612	56	665	72
275	138	337D	153	522	79	570	134	612a	56	666	141
276D	142	338	150	523	79	571	134	612b	56	667	141
277	142	338D	155	524	79	579	36	617	57	668	141
278	142	339	144	525	80	580	56	617a	57	669	19
279	142	340	144	526	80	580a	56	617b	57	669a	61
280	144	341	128	527	80	580b	56	617c	57	669s	61
281	144	T344	149	528	80	581	50	619	65	670	19
282	145	T344D	153	529	80	583	49/57	620s	65	671	19
283	145	345	136	530	81	583a	57	620d	65	672	19
284	145	346	101	531	81	584	49	621	65	673	19
285	145	347s	101	531D	94	585	18	622	65	674	28
286	146	347d	101	532	81	585a	62	623s	65	675	157
287	146	348	101	533	81	585s	62	623d	65	676	157
288	146	349	101	535	82	586	16	624	65	677	157
289	146	350	101	536	82	587	36	625	65	678	17
290	146	351	101	537	82	588	36	626	72	679	49
291	146	352	101	538	83	589	36	627	72	681	59
292	146	353	100	539	83	590	36	628	72	682	51
293	146	354	136	540	83	591	36	629	72	683	11
295	147	355	136	541	83	592	36	631	38	684	51
296	147	356D	111	542	83	593	36/58	632	38	685	51
297	147	357	68	543	84	593a	58	633	38	686	22
298	147	500	74	544	84	595	37	633a	60	687	19
300D	124	501	74	545	84	596	37	633s	60	688	36
301	136	502	74	546	84	597	37	634	38	689	22
302	136	503	74	547	85	598	37	635	38	690	22
303	136	503D	94	548	85	599	37	636	38	691	51
306	149	504	75	549	85	600	37	636a	60	692	51
306D	153	505	75	550	85	601	37	637	38	693	51
307	149	506	75	551	85	602	37	637D	44	694	51
307D	155	507	75	552	86	603	56	638	65	695	51
308D	111	507D	95	553	86	603a	56	639	65	696	23
309D	111	508	76	554	86	604	56	641	65	697	22
319	141	509	76	555	86	604a	56	642	65	698	23
320	141/146	510	76	556	86	605	56	643	65	699	29
322	144	510D	94	557	86	605a	56	645	67	699a	29
323	145	511	76	558	86	606	56	647	67	699s	29
324	145	512	76	559	87	606a	56	649	65	700	23
325	146	513	77	560	87	608	56	651	65	701	23
325bis	146	514	77	561	72	608a	56	652	65	701a	61
326	144	515	77	562	87	608b	56	657D	124	701s	61
327	145	516	77	563	87	609	56	658D	124	702	33
328	145	517	78	564	87	609a	56	659	72	703	35
329	146	518	78	565	87	610	56	661D	124	703D	44

Indice

per articolo



ARTICLE INDEX

ARTICOLO	PAGINA	ARTICOLO	PAGINA	ARTICOLO	PAGINA	ARTICOLO	PAGINA	ARTICOLO	PAGINA	ARTICOLO	PAGINA
704	35	817	29	863	141	912	26	956	52	995	90
705	33	818	34	864	141	913	27	957	53	996	90
706	35	819	34	865	141	914	32	957D	44	996D	95
706D	45	820	34/58	866	146	915	27	958	53	997	90
707	35	820a	58	867	146	916	27	959	53	997D	94
708	130	821	35	868	144	917	27	960	53	998	90
709	100	822	35	869	144	918	59	961	53	998D	95
713	124	823	48	870	146	919	47	962	53	999	91
713D	124	824	48	872	146	920	30	963	53	1000	91
714	137	825	49	877	157	921	30	964	54	1001	91
714a	137	826	49	878	157	922	30	965	54	1001D	95
715	137	827	50	879	157	923	30	966	54	1002	91
717D	117	828	50	880	19	924	31	967	54	1003	91
718D	113	829	50/58	881	19	925	31	968	54	1004	92
719	65	829a	58	882	19	926	39	969	54	1005	92
720	65	830	50	883	157	927	39	970	54	1006	92
721	65	831	50	884	157	928	39	971	54	1007	92
722D	124	832	67	885	157	929	39	972	66	1008	92
723D	123	833	65	886	157	930	40	973	66	1009	102
724	124	834	132	887	157	931	40	974	66	1009s	102
790	82	835D	114	888	157	932	40	975	66	1009d	102
790D	96	836D	114	889	157	933	40	976	66	1010	102
795	8	837D	112	890	157	933D	44	977	66	1011	102
796	8	838D	112	891	157	934	40	978s	66	1012	102
797	8	839D	112	892	11	935	41	978d	66	1013D	116
798	8	840D	115	893	11	936	41	979s	66	1014D	116
799	8	841D	115	894	11	937	41	979d	66	1015D	118
800	15	842D	115	895	11	938	41	980s	66	1016D	118
801	16	843D	115	896	157	939	41	980d	66	1017D	118
802	16	844D	115	897	157	940	41	981s	66	1018D	118
803	16	845D	115	898	24	941	41	981d	66	1019D	118
804	16	846D	115	898a	61	941D	45	982	66	1020D	118
805	17	847D	117	898s	61	942	41	983	66	1021D	118
806	11	848D	117	899	24	943	42	984	66	1022D	119
807	17	849D	117	900	24	944	42	985	66	1023D	119
808	9	850D	117	901	24	945	42	986	66	1024D	119
809	18	851D	117	902	24	946	42	987	66	1025D	119
809a	62	852D	117	903	25	947	42	988	88	1026D	119
809s	62	853D	117	904	25	948	52	988foto	98	1027D	119
810	18	854D	113	905	18	949	52	989	88	1028D	120
810a	62	855D	113	906	25	950	52	990	88	1029D	120
810s	62	856D	117	907	26	951	52	991	89	1030D	120
811	20	857	137	908	26	951D	45	992	89	1033D	120
812	20	858	137	908a	60	952	52	992D	96	1034D	120
813	20	859	137	908s	60	953	52	993	89	1035D	120
814	21	860	137	909	26	954	52	993D	95	1036D	121
815	21	861	141	910	26	955	52/58	994	90	1037D	121
816	28	862	141	911	26	955a	58	994D	96	1038D	121

Indice

Indice

per articolo



ARTICLE INDEX

ARTICOLO	PAGINA	ARTICOLO	PAGINA	ARTICOLO	PAGINA	ARTICOLO	PAGINA	ARTICOLO	PAGINA	ARTICOLO	PAGINA
1039D	121	1091	72	C9ø16-21	150/151						
1040D	121	1092D	134	C10ø16	154	446	165	1177	158		
1041D	121	1093	134	C11ø21	154	447	165	1178	158		
1042D	121	1094	134	C12ø26	155	1131	64	1179	158		
1043D	121	1095	134	Bc8ø13	155	1132	162	1180	159		
1044D	121	1096	135	Crø10	152	1133	162	1181	159		
1045D	121	1097	135	Crø13	149	1134	162	1182	159		
1046D	122	1098	135	Crø16	152/154	1135	162	1183	159		
1047D	122	1099	135	Crø21	149/154	1136	160	1184	159		
1048D	122	1100	135	Crø26	149/155	1137	160	1185	159		
1049D	122	1101	135	Clø10	150/152	1138	160	1186	162		
1050D	122	1102	140	Clø13	149	1139	160	1188	162		
1051D	122	1103D	140	Clø16	150/152	1140	160	1244	164		
1052D	122	1104D	140	Clø21	150	1141	160	1247	164		
1053D	122	1105	140	Clø26	150	1142	160				
1054D	123	1106	140	Ccø16-21	151	1145	161				
1055D	123	1107	140	Ccø21-26	151	1146	161				
1056D	123	1108D	140	Cbø21	151	1147	161				
1057D	123	1109	140	B2ø10	150/152	1148	161				
1058D	123	1110	140	B2ø13	149	1149	161				
1059D	123	1111	140	B2ø16	150/152	1150	163				
1060D	123	1112	140	B2ø21	149/154	1151	162				
1061	68	1113	147	B2ø26	149/155	1152	162				
1062	68	1114	147			1154	161				
1063	130	1115	145			1155	163				
1064	130	1116	145			1156	163				
1065	131	1117	145			1157	163				
1066	131	1118	147			1158	163				
1067	131	1119	147			1159	163				
1068	131	1120	147			1160	161				
1072	131	1121	59/147			1161	161				
1073	131	1122	147			1162	161				
1074	131	1123	145			1163	157				
1075	132	1124	145			1164	157				
1076	132	1125	145			1165	157				
1077	132	1126	145			1166	157				
1078	132	1127	145			1168	157				
1079	132	1128	145			1169	157				
1080	132	1129	109			1170	157				
1081	132	1130D	156			1171	158				
1082	132	C1ø13	149			1172	158				
1083	72	C2ø10	152			1173	158				
1084	132	C3ø16	152			1174	158				
1085	132/147	C4ø26	149/150			1175	163				
1086	132	C5ø21	149/151			1175a	163				
1087	132	C6ø21	149/153			1175b	163				
1088	132	C7ø16	152			1176	158				
1089	132	C8ø13	155								

Novità 2021

L.V. STUCCHI

*Manufatti
in gesso*
PLASTER MANUFACTURED



Stand L.V. Stucchi MADE expo 2010 - Milano

L.V. STUCCHI

*Manufatti
in gesso*

PLASTER MANUFACTURED



Le Cornici

The frames

Cornici lineari

LINEAR FRAMES



Art. C 240

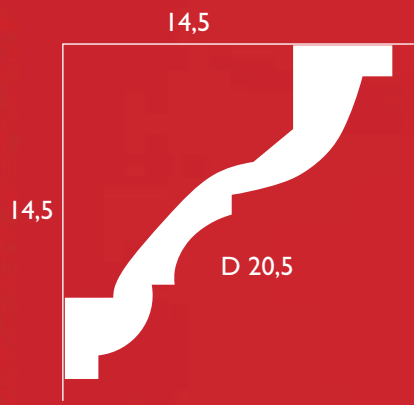

Art. C 795

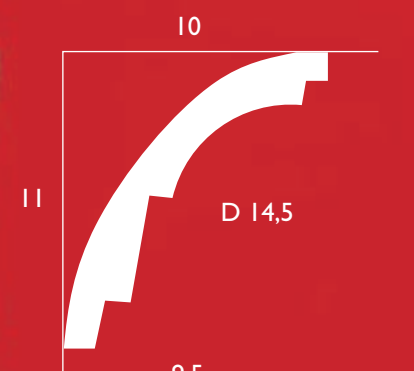

Art. C 796

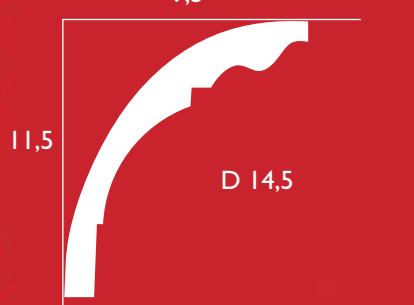

Art. C 797

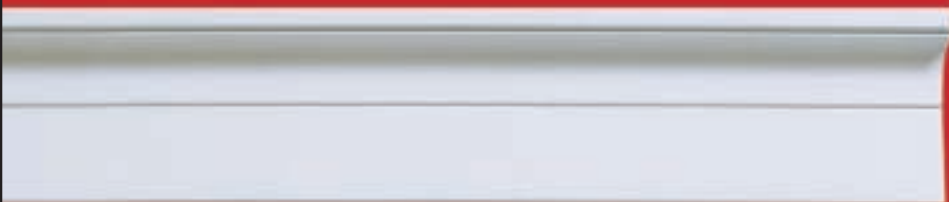

Art. C 798

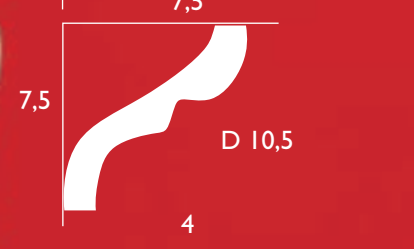

Art. C 799



Cornici lineari

LINEAR FRAMES



Art. C 171

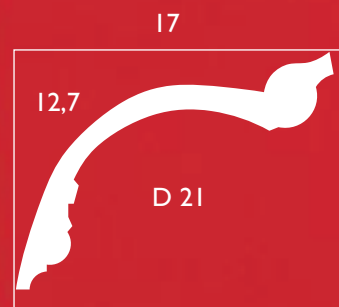
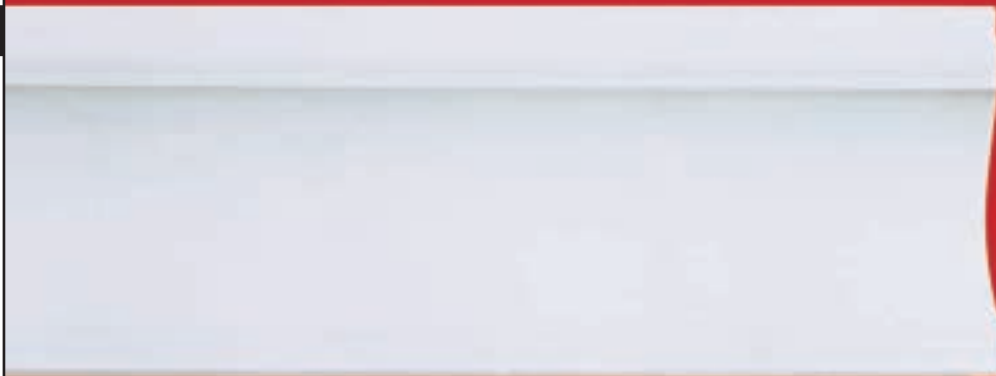

Art. C 808

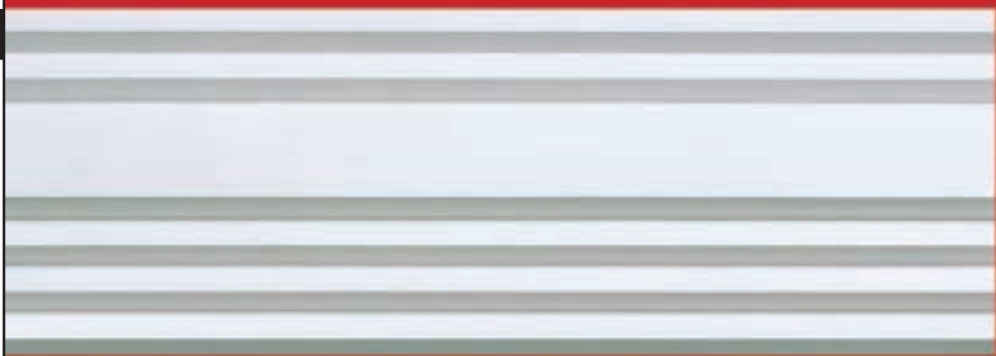

Art. C 210

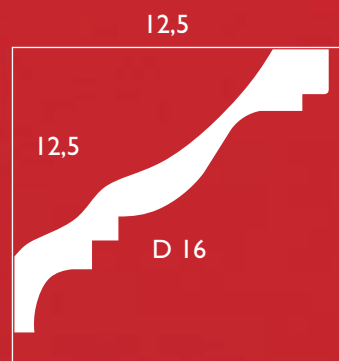

Art. C 231

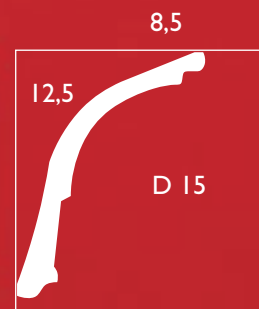

Cornici lineari

LINEAR FRAMES



Art. **C 201**

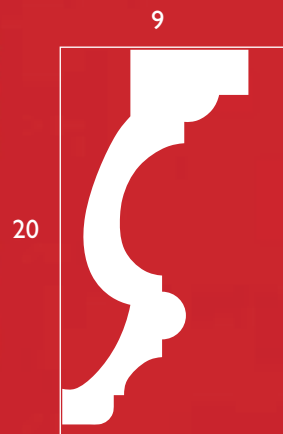

Art. **C 239**



Art. **C 212**



Art. **C 209**



Art. **C 215**





Art. **C 225**

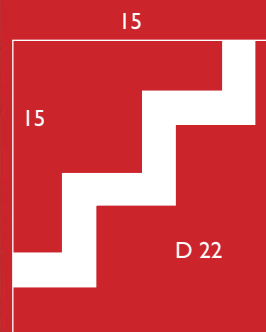

Art. **C 892**

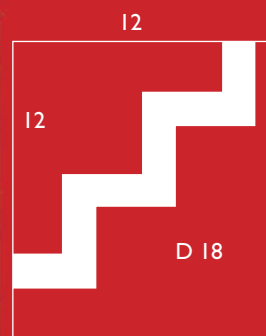

Art. **C 223**

Disponibili anche
Available:
C 893 - 18x18
C 894 - 24x24
C 895 - 30x30

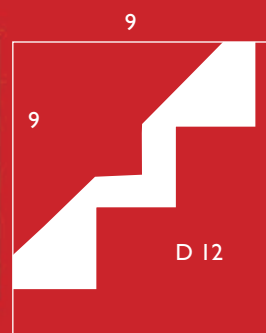

Art. **C 806**

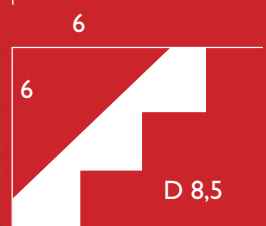

Art. **C 683**

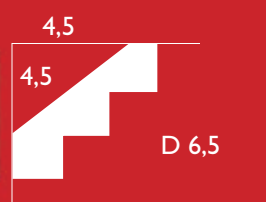

Cornici lineari

LINEAR FRAMES



Art. C 229

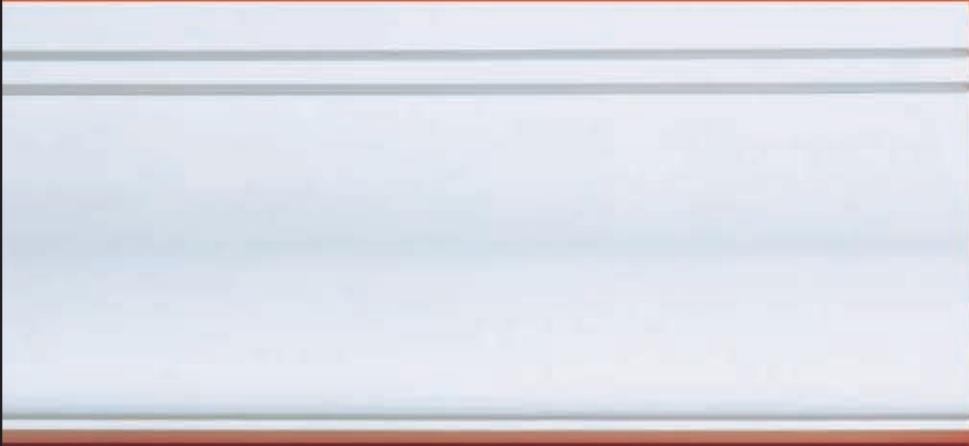

Art. C 220

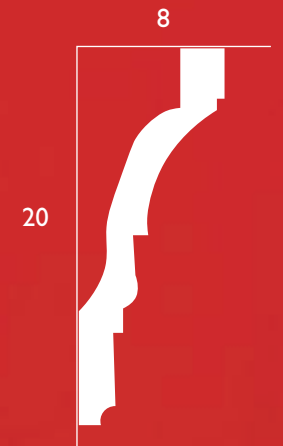

Art. C 211

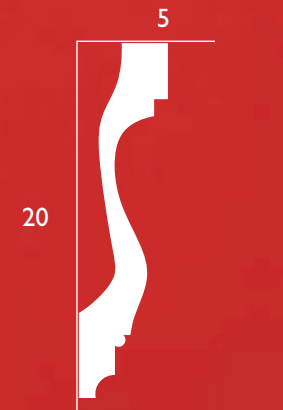

Art. C 221

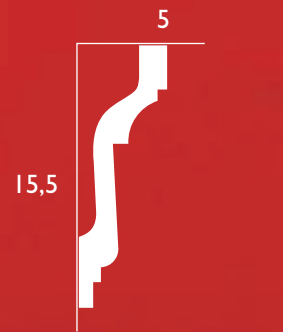

Cornici lineari

LINEAR FRAMES



Art. C 172

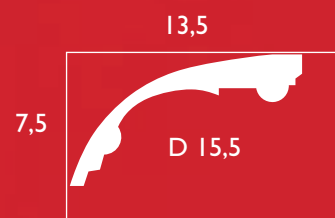

Art. C 175

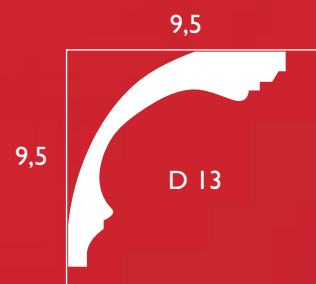

Art. C 222



Art. C 184

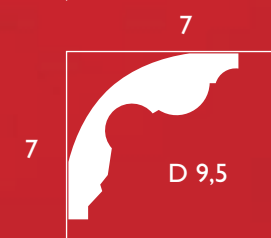

Art. C 185

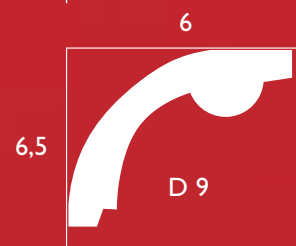

Art. C 188

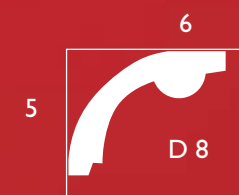

Art. C 190



Cornici lineari

LINEAR FRAMES



Art. C 191



3

3



Art. C 218



3

5



Art. C 214



6

10,5



Art. C 217



3,5

7



Art. C 163



3

6,5



Art. C 216



3

6



Art. C 164



2

6,5



Art. C 219



1,5

4,5



Cornici lineari

LINEAR FRAMES



Art. **C 233**

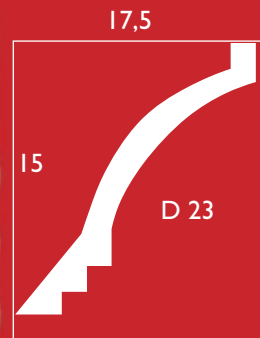

Art. **C 230**

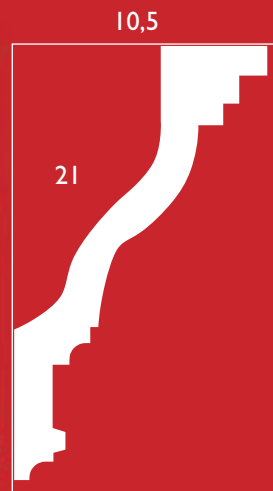

Art. **C 235**



Art. **C 800**



Art. **C 99**

NEW



Cornici lineari

LINEAR FRAMES



Art. **C 801**

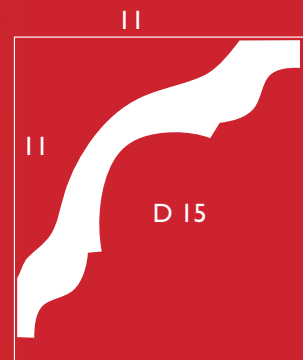

Art. **C 803**

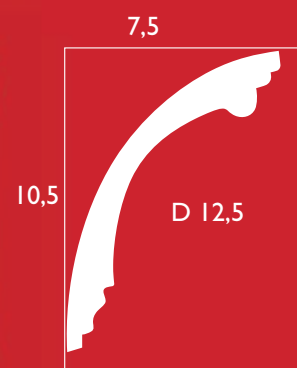
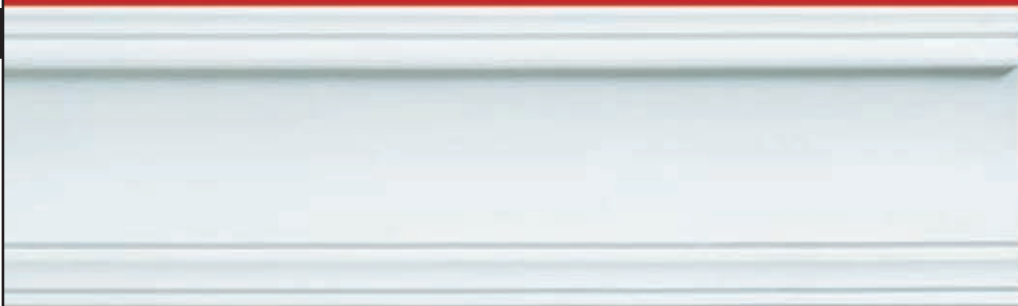

Art. **C 804**

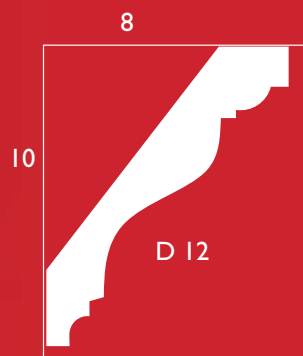

Art. **C 802**



Art. **C 586**

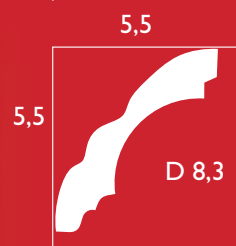

Cornici lineari

LINEAR FRAMES



Art. **C 805**

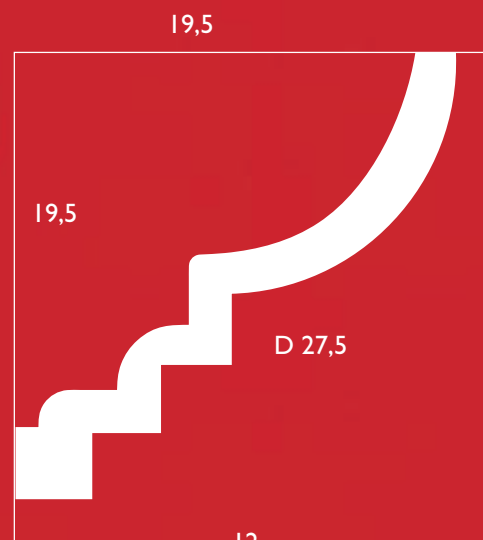

Art. **C 100**
NEW



Art. **C 678**

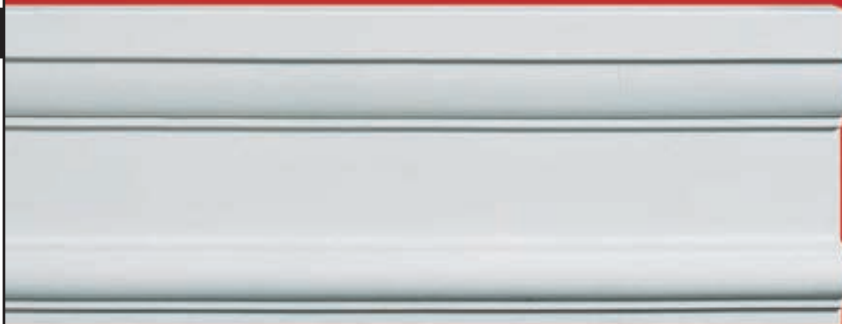

Art. **C 807**



Cornici lineari

LINEAR FRAMES



Art. **C 905**

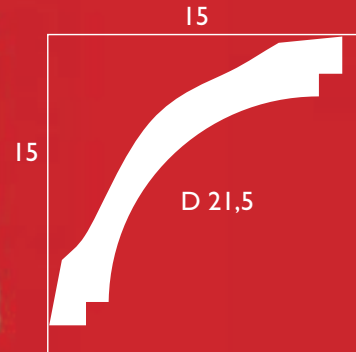
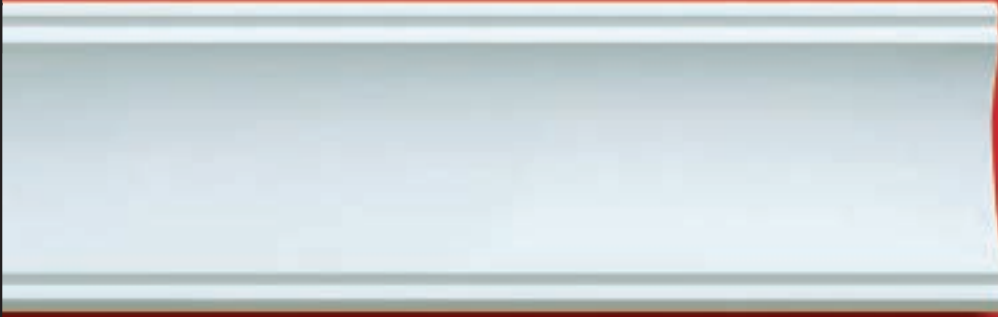

Art. **C 809**

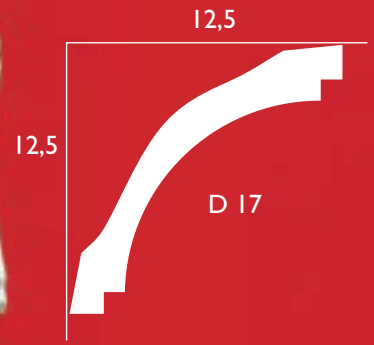

Art. **C 585**

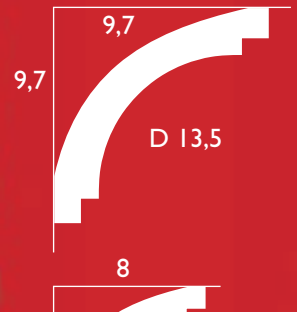

Art. **C 810**

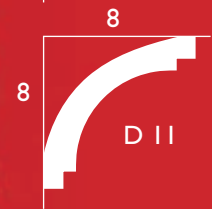

Art. **C 187**

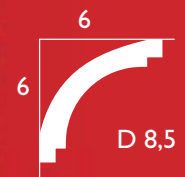
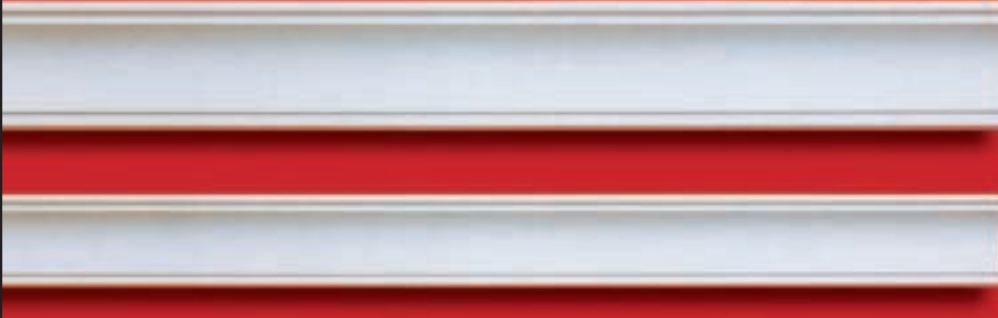

Art. **C 189**

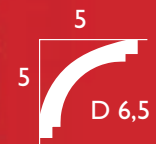
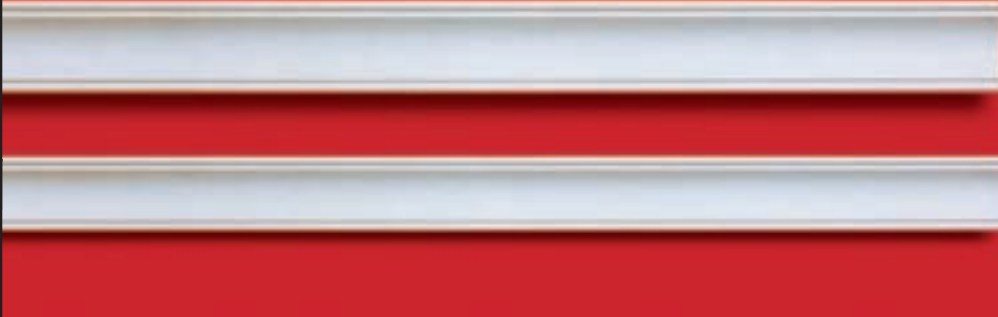

Art. **C 101**

NEW





Art. C 669

*

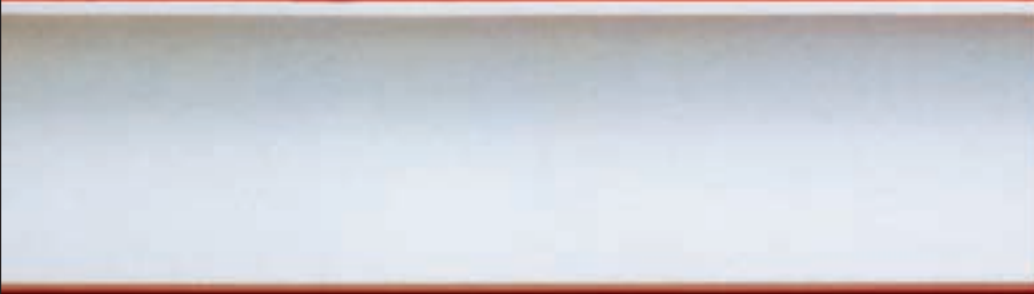

15

15



Art. C 203

*

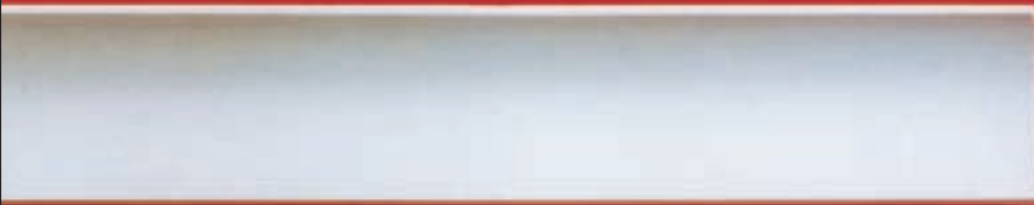

9,5

9,5



Art. C 204

*



7

7



Art. C 205

*



4

4



Art. C 687

*



3

3



Art. C 202



9,5

9,5



Art. C 186



7,5

7,5



* Disponibili anche / Available:

Art. C 880 - 17x17

Art. C 102 - 35x35 **NEW**

Art. C 670 - 20x20

Art. C 881 - 40x40

Art. C 671 - 25x25

Art. C 673 - 45x45

Art. C 672 - 30x30

Art. C 882 - 60x60

Cornici lineari

LINEAR FRAMES



Art. **C 811**

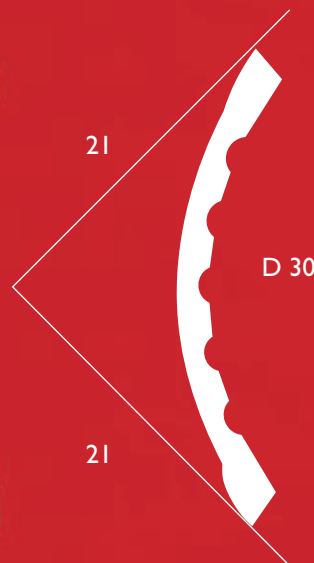

Art. **C 812**

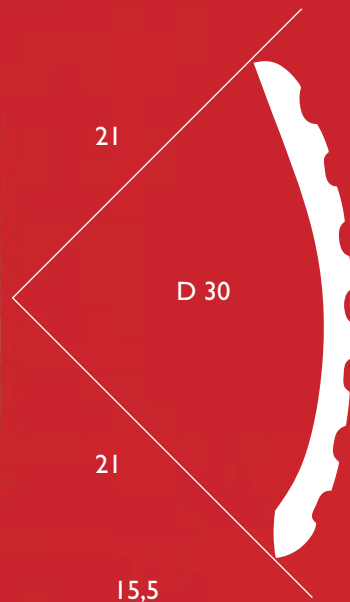

Art. **C 813**

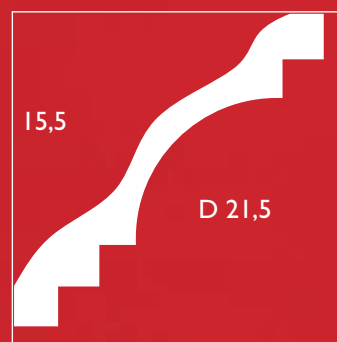



Cornici lineari

LINEAR FRAMES



Art. C 814



Art. C 815



Cornici lineari

LINEAR FRAMES

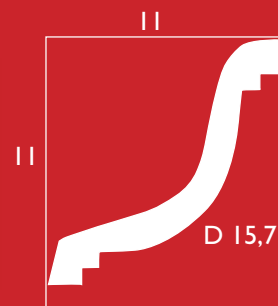
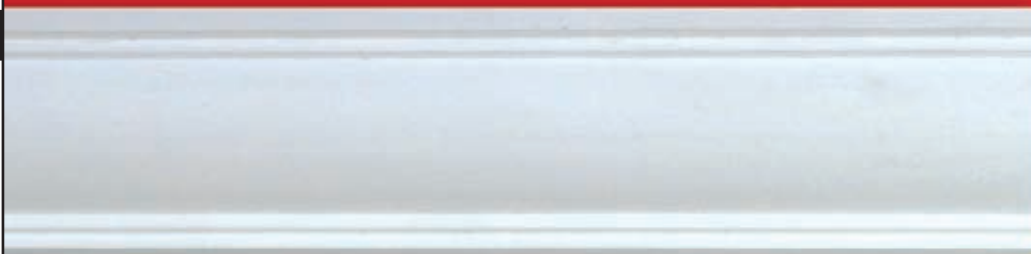
Art. **C 103****NEW**Art. **C 697**

*

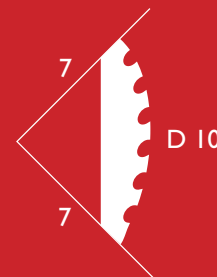
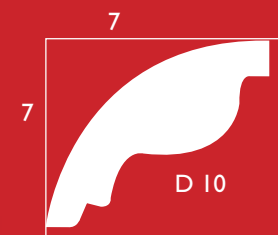
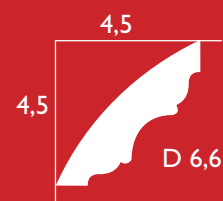
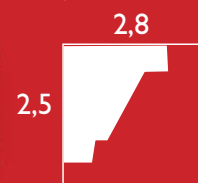
Art. **C 689**Art. **C 686**Art. **C 690**Art. **C 104****NEW**Art. **C 105****NEW**

* Anche per gli angoli / Even for the angles.

Cornici lineari

LINEAR FRAMES



Art. C 698

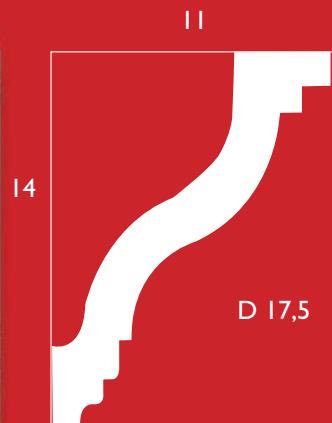

Art. C 701

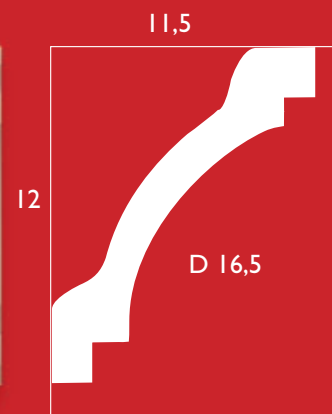

Art. C 700

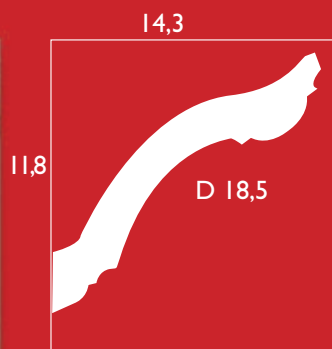

Art. C 696



Cornici lineari

LINEAR FRAMES



Art. **C 898**

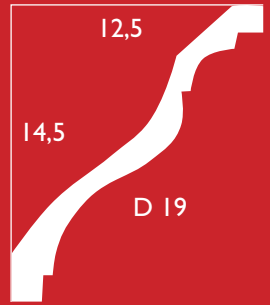

Art. **C 899**

Componibile con articolo / Fitted with article C 931

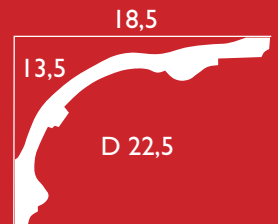

Art. **C 900**

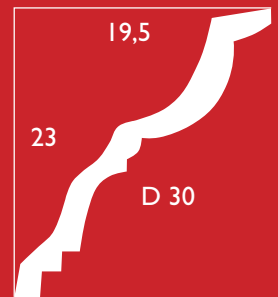
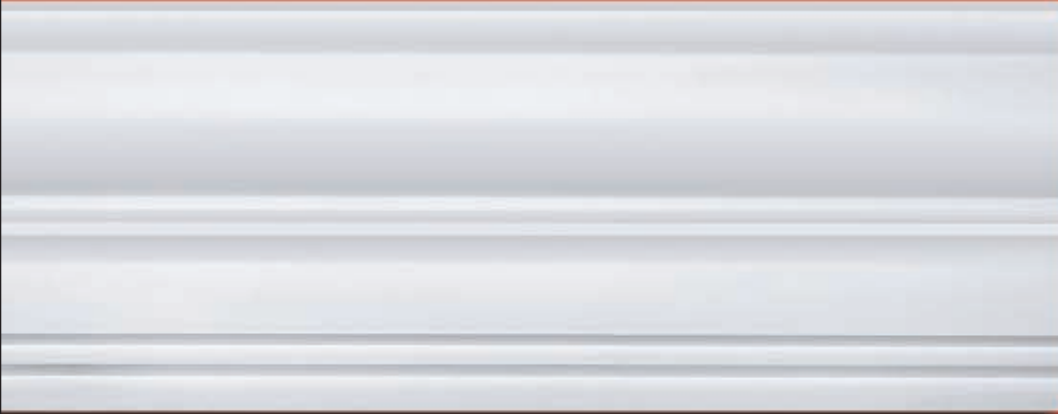

Art. **C 901**

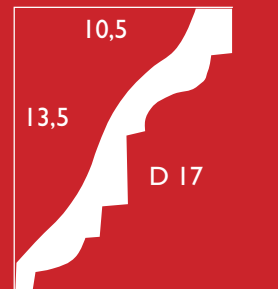

Art. **C 902**



Cornici lineari

LINEAR FRAMES



Art. **C 904**

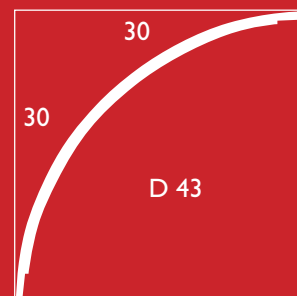
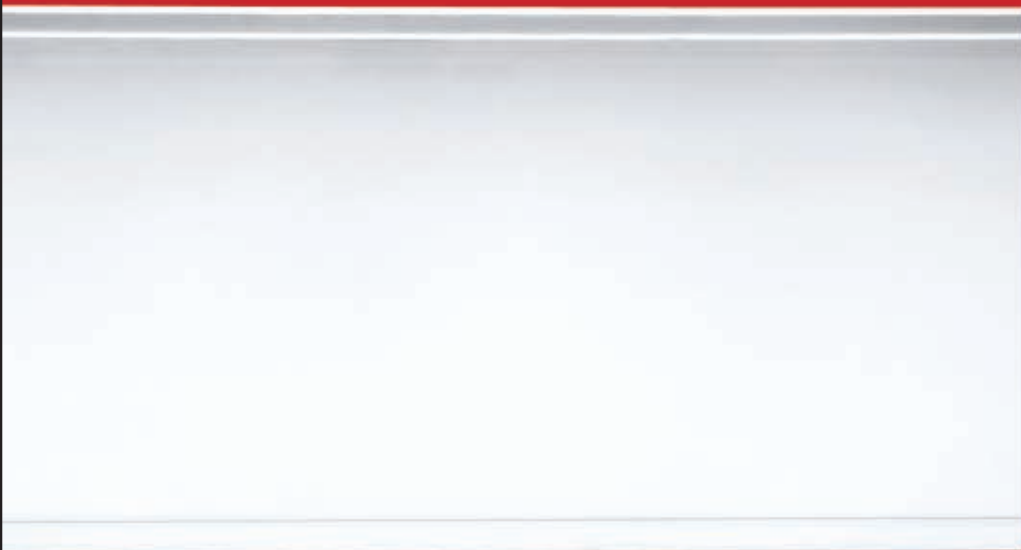

Art. **C 903**

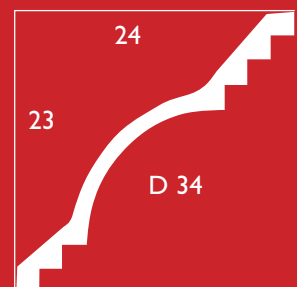

Art. **C 106**

NEW

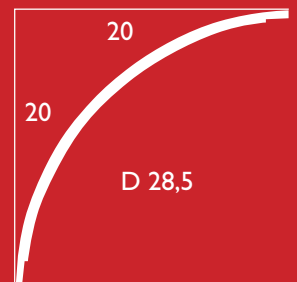

Art. **C 906**



Art. **C 907**

Componibile con articolo / Fitted with article C 930

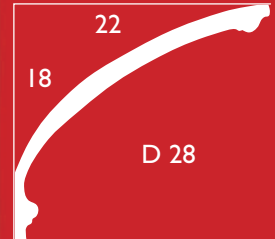
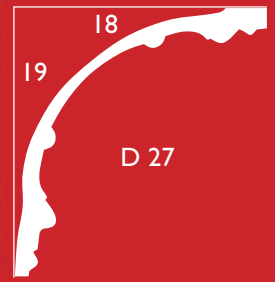
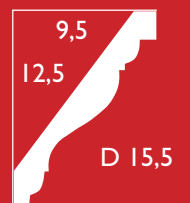
Art. **C 908**Art. **C 909**Art. **C 910**Art. **C 911**Art. **C 912**

Cornici lineari

LINEAR FRAMES



Art. **C 107**
NEW

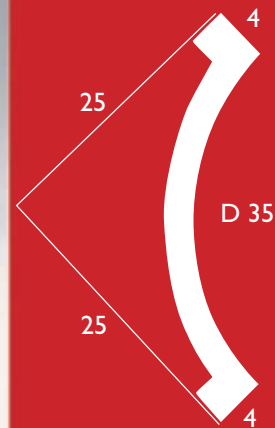
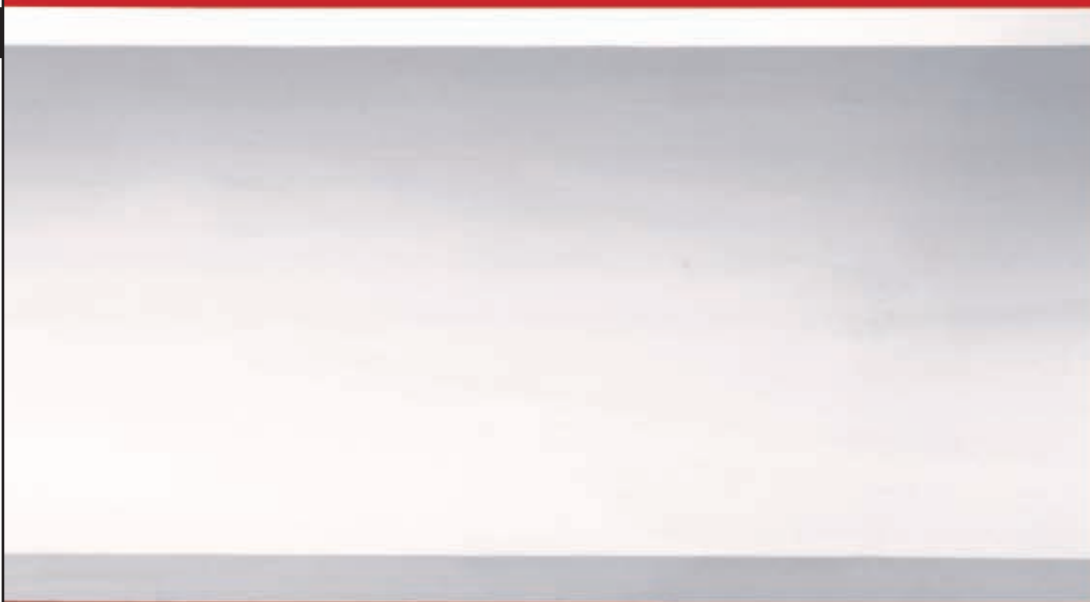

Art. **C 913**

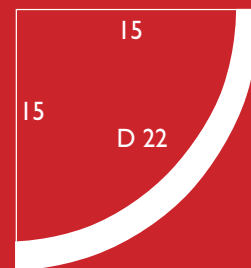

Art. **C 915**

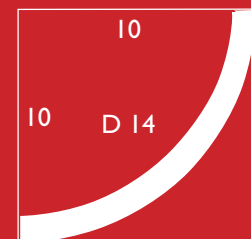

Art. **C 916**

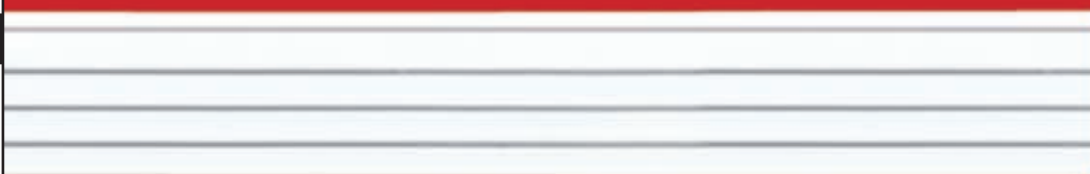

Art. **C 917**



Cornici fondi luce

FRAMES LIGHT DIFFUSERS



Art. **C 816**

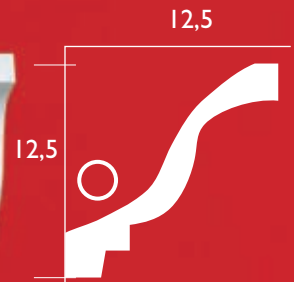

Art. **C 674**



Art. **C 224**



Art. **C 168**

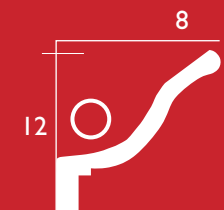
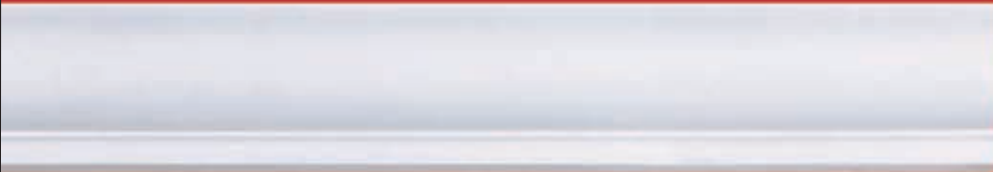

Art. **C 167**

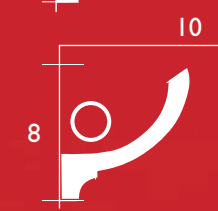

Art. **C 232**

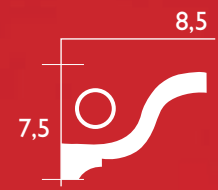

Art. **C 166**



Cornici fondi luce

FRAMES LIGHT DIFFUSERS



Art. C 167 a

Art. C 167

Art. C 167 s



Art. C 168 a

Art. C 168

Art. C 168 s



Art. C 699

Spazio per luce a neon

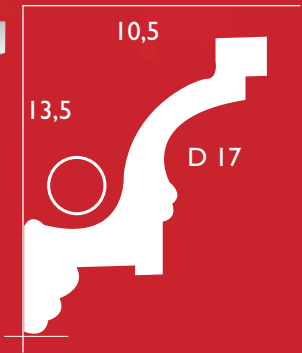

Art. C 699 a



Art. C 699 s



Art. C 817



Cornici fondi luce

FRAMES LIGHT DIFFUSERS



Art. C 920

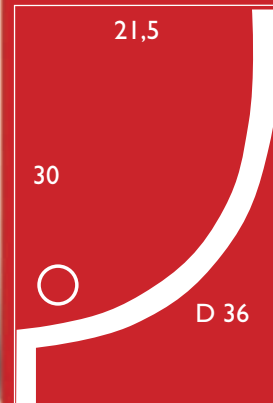

Art. C 921



Art. C 922

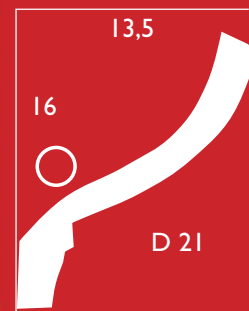

Art. C 923

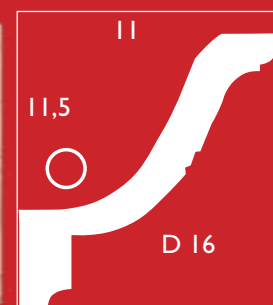

Cornici fondi luce

FRAMES LIGHT DIFFUSERS



Art. **C 108**
NEW

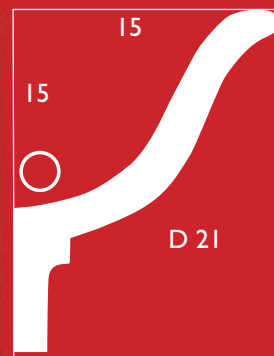

Art. **C 924**

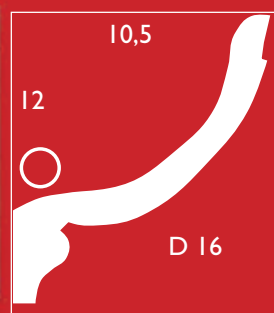

Art. **C 925**

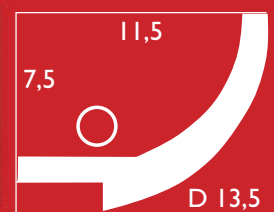

Cornici lavorate

WORKED FRAMES



Art. **C 109**
NEW

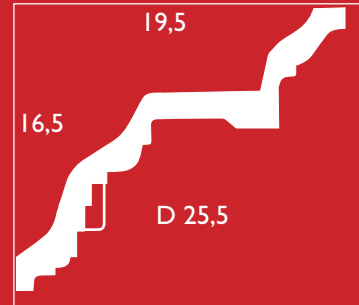

Art. **C 110**
NEW

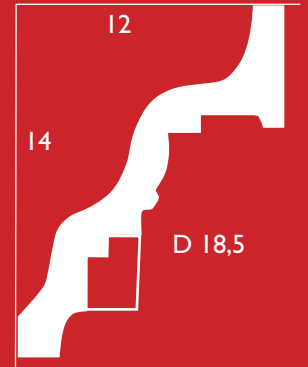

Art. **C 914**



Art. **C 213**



Cornici lavorate

WORKED FRAMES



Art. **C 111**
NEW



Art. **C 226**

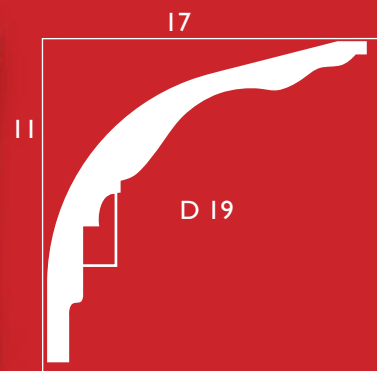

Art. **C 112**
NEW

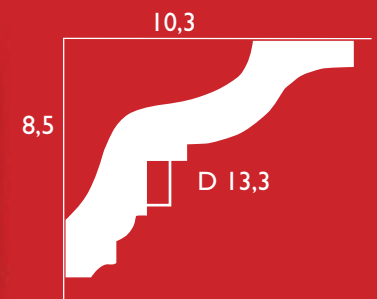

Art. **C 702**

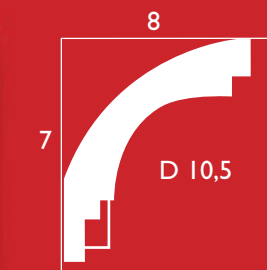

Art. **C 705**



Cornici lavorate

WORKED FRAMES



Art. C 237



Art. C 238



Art. C 228



Art. C 818



Art. C 819



Art. C 820



Cornici lavorate

WORKED FRAMES



Art. C 821



Art. C 822



Art. C 703



Art. C 704



Art. C 706



Art. C 707



Cornici lavorate

WORKED FRAMES



Art. C 587



6,5

2

Art. C 588



7

2

Art. C 589



5,5

2

Art. C 590



5,8

2

Art. C 591



4,8

2

Art. C 592



5

2

Art. C 593



3,5

1,5

Art. C 579



6

2,3

Art. C 688



11

5,7

Cornici lavorate

WORKED FRAMES



Art. C 595



Art. C 596



Art. C 597



Art. C 598



Art. C 599



Art. C 600



Art. C 601



Art. C 602



Cornici lavorate

WORKED FRAMES



Art. C 631

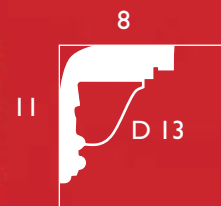

Art. C 632

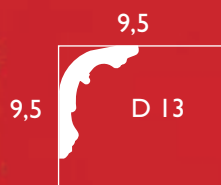

Art. C 633

Disponibile
angolo
e spigolo
Available
corner
and edge

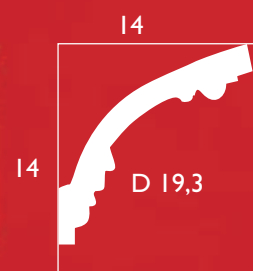

Art. C 634

Disponibile
angolo
e spigolo
Available
corner
and edge

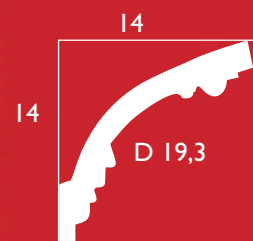

Art. C 635

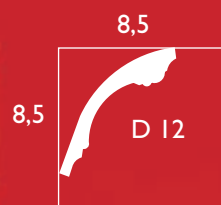

Art. C 636

Disponibile
angolo
Available
corner

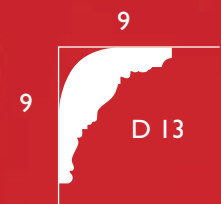

Art. C 637

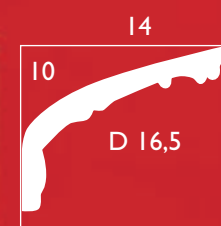

NON DISPONIBILE

Cornici lavorate

WORKED FRAMES



Art. C 926

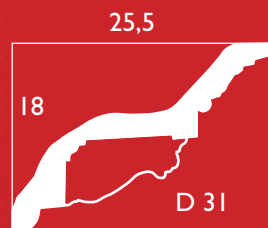

Art. C 927

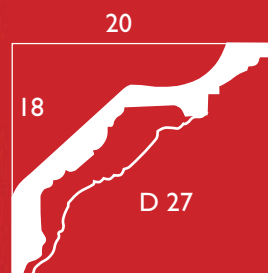

Art. C 928

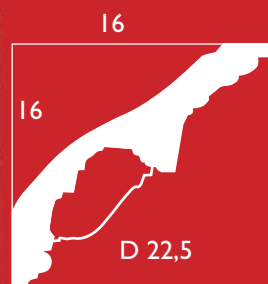

Art. C 929

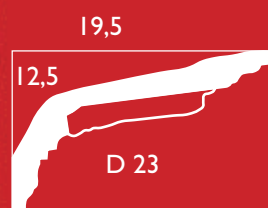

Cornici lavorate

WORKED FRAMES



Art. **C 930**

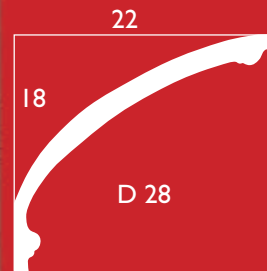

Art. **C 931**



Art. **C 932**



Art. **C 933**



Art. **C 934**



Cornici lavorate

WORKED FRAMES



Art. C 935



Art. C 936



Art. C 937



Art. C 938

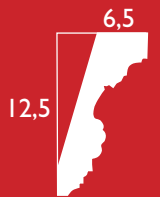

Art. C 939



Art. C 940



Art. C 941



Art. C 942



Cornici lavorate

WORKED FRAMES



Art. C 943

Applicabile anche al contrario / Applicable also in the opposite

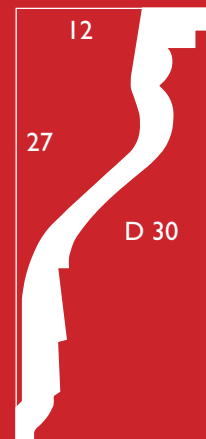

Art. C 944

Applicabile anche al contrario / Applicable also in the opposite

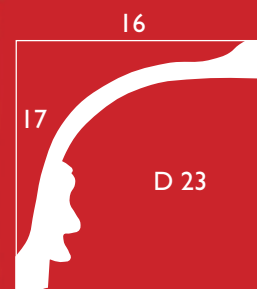

Art. C 945



Art. C 946



Art. C 947



Cornici lavorate

WORKED FRAMES



Art. **C 113**
NEW

NON DISPONIBILE



9,1

10

D 13,5



Art. **C 114**
NEW



4,3

10,2



Art. **C 115**
NEW



3,5

9,7



Art. **C 116**
NEW



8,2

9,2



Art. **C 96**
NEW



3,6

15,7



Art. **C 97**
NEW



7,7

11



Cornici lavorate

WORKED FRAMES



Art. C 237D



Art. C 957D



Art. C 933D



Art. C 637D



Art. C 703D



Cornici lavorate

WORKED FRAMES



Art. C 238D



Art. C 951D



Art. C 941D

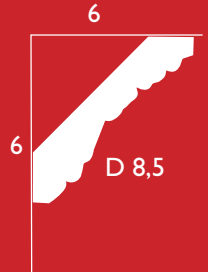

Art. C 706D



Cornici mezza altezza

HALF HEIGHT FRAMES

**NEW**

Art. **C 90**
72x6,8

**NEW**

Art. **C 91**
72x6,8

**NEW**

Art. **C 90D**
72x6,8

**NEW**

Art. **C 91D**
72x6,8

**NEW**

Art. **C 92D**
71x7

**NEW**

Art. **C 93D**
71x7

**NEW**

Art. **C 93**
71x7

**NEW**

Art. **C 92**
71x7























E sempio di montaggio, la giuntura è a vista / Mounting example, the joint is exposed.

Cornici mezza altezza

HALF HEIGHT FRAMES























Art. C 117 NEW		1,5 6	
	Componibile con articolo / Fitted with article 1009		
Art. C 118 NEW		1,1 5,5	
Art. C 119 NEW *		1,7 4,3	
Art. C 120 NEW		1,9 5	
Art. C 121 NEW		2,1 4,3	
Art. C 122 NEW		1,7 4,5	
Art. C 123 NEW		2,7 4,5	
Art. C 124 NEW *		1,5 3,2	
Art. C 125 NEW *		2 3,5	
Art. C 919		2 2	
Art. C 126 NEW		0,7 1,5	

* Disponibile angolo / Available corner.

Cornici *mezza altezza*

HALF HEIGHT FRAMES



Art. C 206		10	3,5	
Art. C 207		8	4	
Art. C 208		6,5	3	
Art. C 227 *		5	2,4	
Art. C 197 *		4	2,2	
Art. C 823 *		4	2	
Art. C 824 *		3	1,5	
Art. C 193 *		3	1,5	
Art. C 192 *		3,3	1,5	
Art. C 195 *		2,3	1	

* Disponibile angolo / Available corner.

Cornici *mezza altezza*

HALF HEIGHT FRAMES

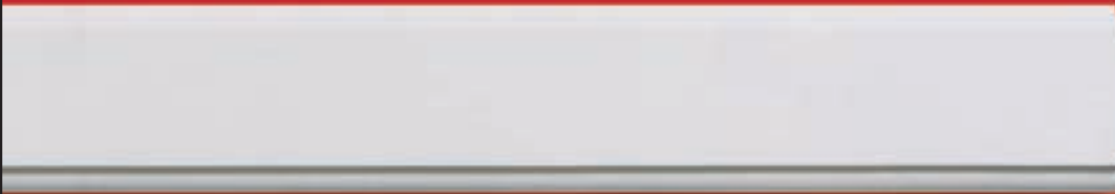
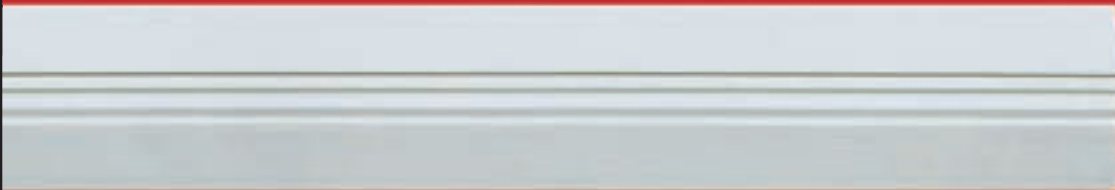
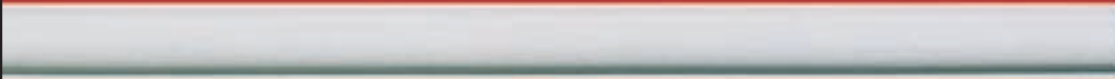
Art. **C 825**Art. **C 236**Art. **C 826**Art. **C 679**Art. **C 127**
NEWArt. **C 584**
*Art. **C 128**
NEWArt. **C 583**
*

* Disponibile angolo / Available corner.

Cornici mezza altezza

HALF HEIGHT FRAMES



Art. **C 581**



13,5

Art. **C 828**

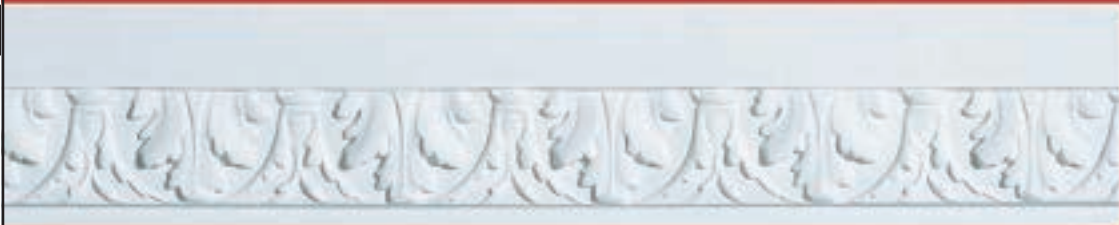

9,7

Art. **C 827**



7

Art. **C 829**

*



5

Art. **C 831**



4,5

1,8

Art. **C 129**

NEW
*



5,8

2,2

Art. **C 830**

*



2

1,5

* Disponibile angolo / Available corner.

Cornici mezza altezza

HALF HEIGHT FRAMES



Art. **C 694**

Battiscopa

su ordinazione anche più basso

Skirting

custom even lower



Art. **C 695**

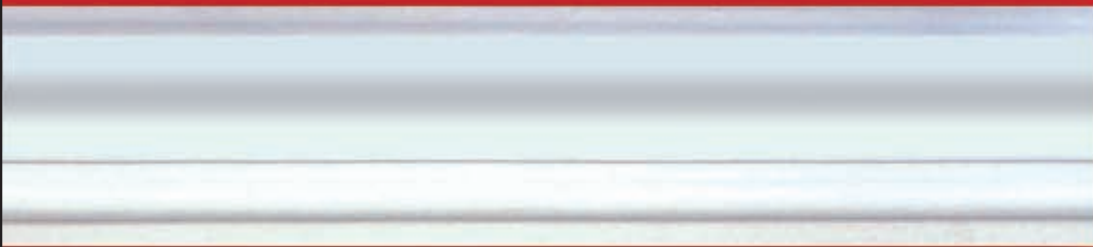

Art. **C 682**



Art. **C 685**



Art. **C 684**



Art. **C 693**

*



Art. **C 692**

*



Art. **C 691**



* Disponibile angolo / Available corner.

Cornici mezza altezza

HALF HEIGHT FRAMES



Art. C 948



Art. C 949



Art. C 950



Art. C 951



Art. C 952



Art. C 953



Art. C 954



Art. C 955

*



Art. C 956



* Disponibile angolo / Available corner.

Cornici *mezza altezza*

HALF HEIGHT FRAMES



Art. **C 957**



Art. **C 958**



Art. **C 959**



Art. **C 960**



Art. **C 961**



Art. **C 962**



Art. **C 963**



Cornici mezza altezza

HALF HEIGHT FRAMES



Art. C 964



Art. C 965



Art. C 966



Art. C 967



Art. C 968



Art. C 969



Art. C 970



Art. C 971



*

* Disponibile angolo / Available corner.

Cornici mezza altezza

HALF HEIGHT FRAMES



Art. **C 70**
NEW



1,8

12,3

Art. **C 71**
NEW



1,8

10,5

Art. **C 72**
NEW



1,5

10

Art. **C 73**
NEW



1,3

2,5

Art. **72 a**
NEW



18,5x18,5



Cornici da riquadro

SQUARE FRAMES

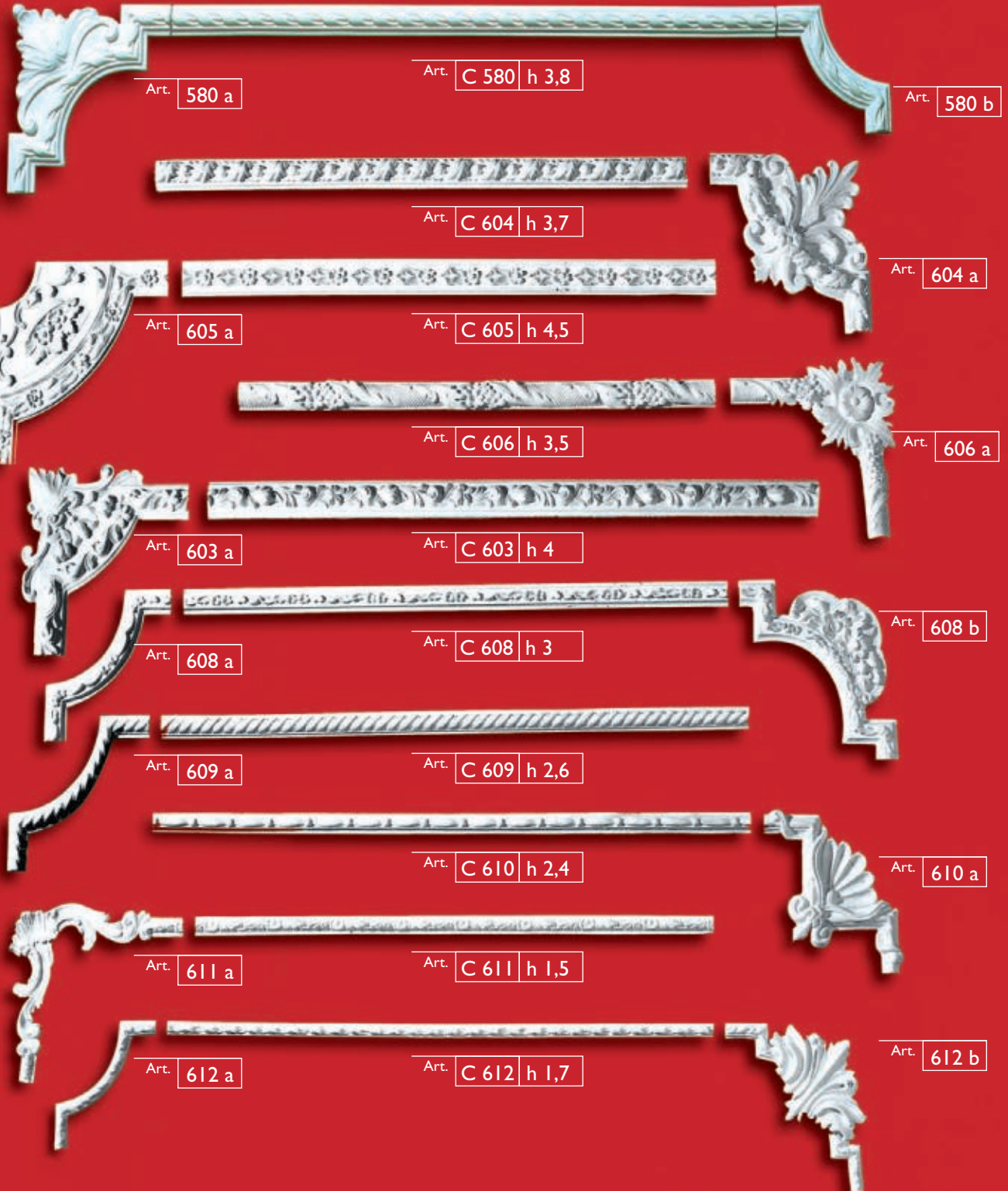

Cornici da riquadro

SQUARE FRAMES

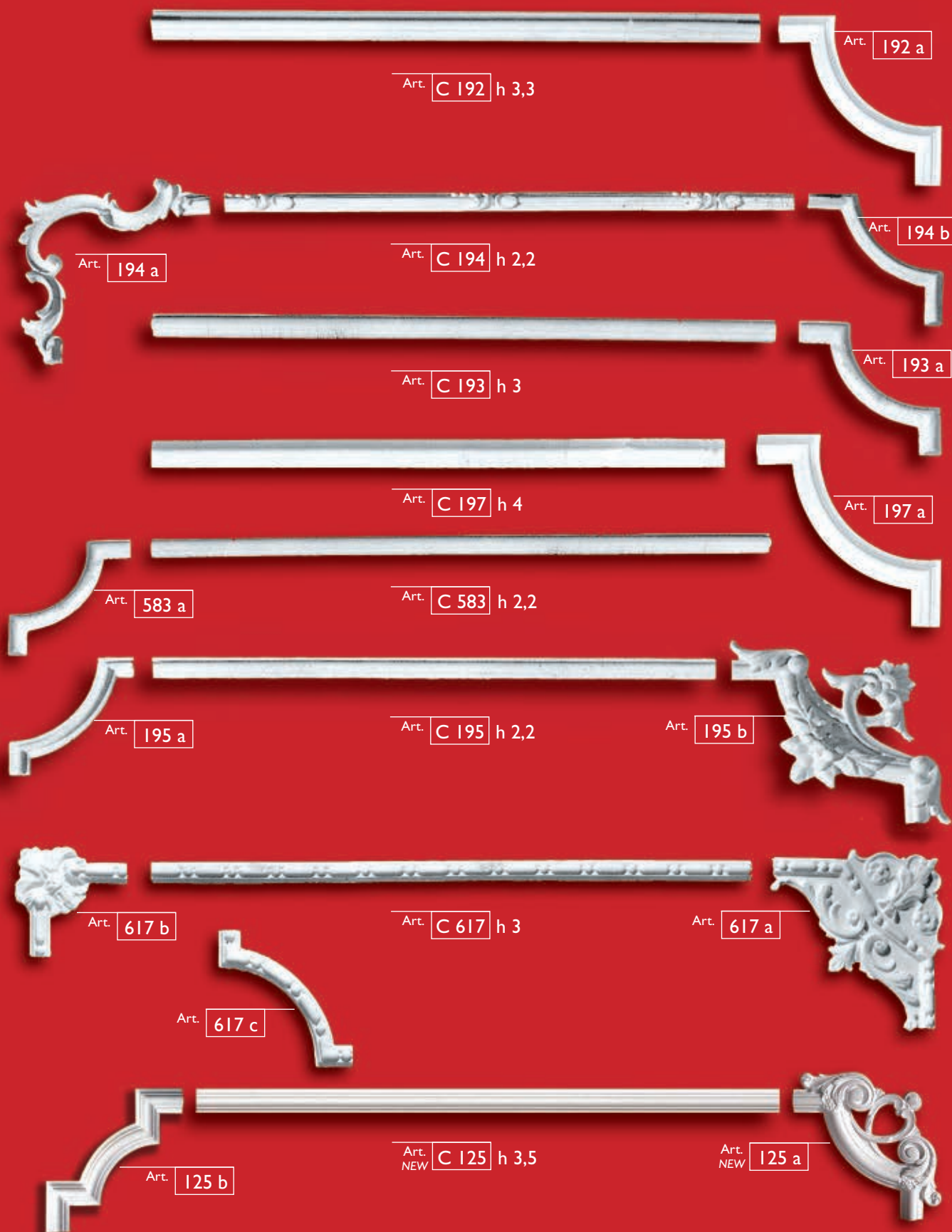

Cornici da riquadro

SQUARE FRAMES



Art. 22 x 17 **955 a**



Art. **C 955** h 5,2



Art. **C 829** h 5



Art. 29 x 29 **829 a**



Art. 38 x 38 **129 a**



Art. NEW **C 129** h 5,5



Art. 25 x 25 **129 b**



Art. NEW **C 124** h 3,2

Art. h 20 **124 c**



Art. 20 x 20 **123 a**



Art. NEW **C 123** h 4,5



Art. **C 593** h 3,5



Art. **593 a**



Art. **820 a**



Art. **C 820** h 4



Art. NEW **C 130** h 2,2



Art. 17 x 17 **130 a**

Cornici *per spigoli*

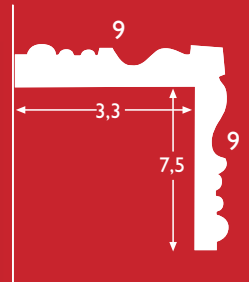
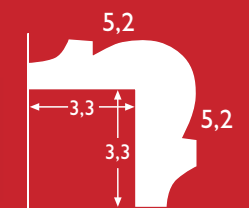
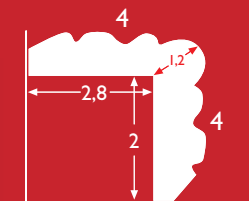
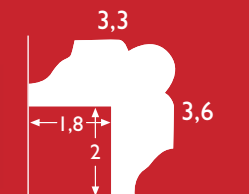
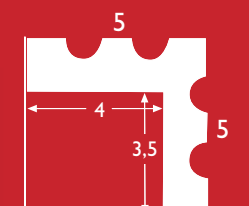

EDGES FRAMES

Art. **C 234**Art. **C 681**Art. **C 131**
NEWArt. **C 918**Art. **C 1121**Art. **C 296**

NEW
Per angoli
For corner

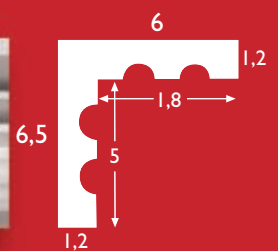

Cornici angoli e spigoli



CORNERS AND EDGES

Art. 633 s



11,5

Art. 633 a



25

Art. 908 a



29

Art. 908 s



10

NON DISPONIBILE

Art. 636 a



29

NON DISPONIBILE

Art. 234 c

raggio / radius 45°



Cornici angoli e spigoli



CORNERS AND EDGES

Art. 669 a

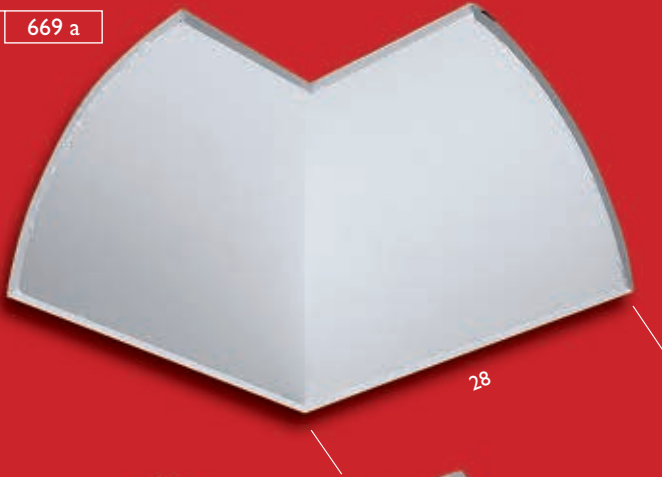

Art. 669 s



Art. 224 a



Art. 224 s



Art. 898 a



Art. 898 s

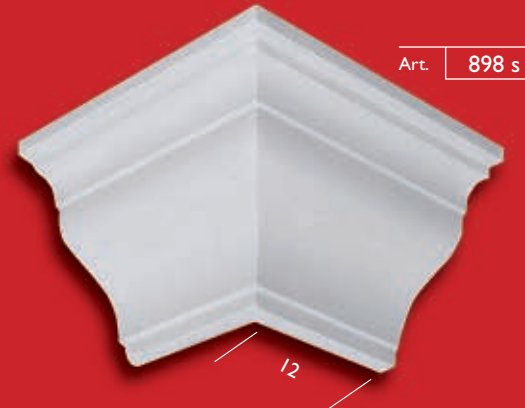

Art. 701 a



Art. 701 s



Cornici *angoli e spigoli*

CORNERS AND EDGES



Art. 809 a



Art. 809 s



Art. 585 a



Art. 585 s



Art. 810 a



Art. 810 s



Art. 202 a



Art. 202 s



L.V. STUCCHI

*Manufatti
in gesso*

PLASTER MANUFACTURED



I Fregi The freizes

Villa Dei Principi - Laterza (Ta)



15

NEW

Art. 1131
35x35



NEW

Art. F 75
53x53



NEW

Art. F 74
84x46



Fregi

FREIZES





Art. F 982
51x10



Art. F 983
40x6



Art. F 981 d
20



Art. F 978 s
75

Art. F 979 s
52

Art. F 980 s
26,5

Art. F 984
19x19



Art. F 981 s
20

Art. F 986
17,5x20

Art. F 987
12





Art. **F 832**
52x35



NEW
Art. **F 134**
56x41

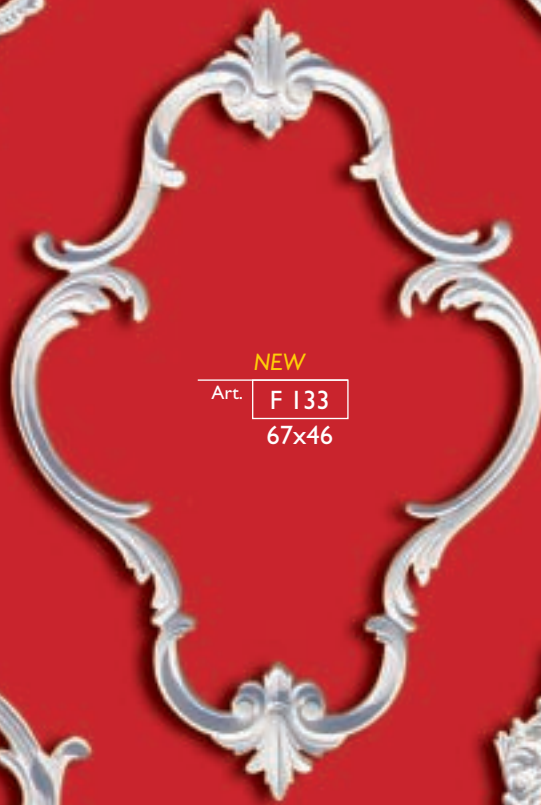

NEW
Art. **F 133**
67x46



Art. **F 645**
34x28



Art. **F 647**
40x31



Mis. est.-est.
ext. ext. measures

- Ø 17,5
- Ø 27,5
- Ø 37
- Ø 47
- Ø 57
- Ø 67

Art. **F 662**



Art. **S 357**
84x74



Scuretto per specchio
Dark mirror for

70x60

Art. **S 1061**
93x73



Scuretto per specchio
Dark mirror for

72x52

NEW
Art. **S 88**
46x36



40x30

NEW
Art. **S 89**
60x50



47x37

Cornice per specchiera / Mirror Frames



Art. **S 1062**

L.V. STUCCHI

*Manufatti
in gesso*

PLASTER MANUFACTURED



Composto da 623 D+S - 12 + 12
981 D+S - 12 + 12
833 - 3



by Vocino Antonio - Apricena (Fg)

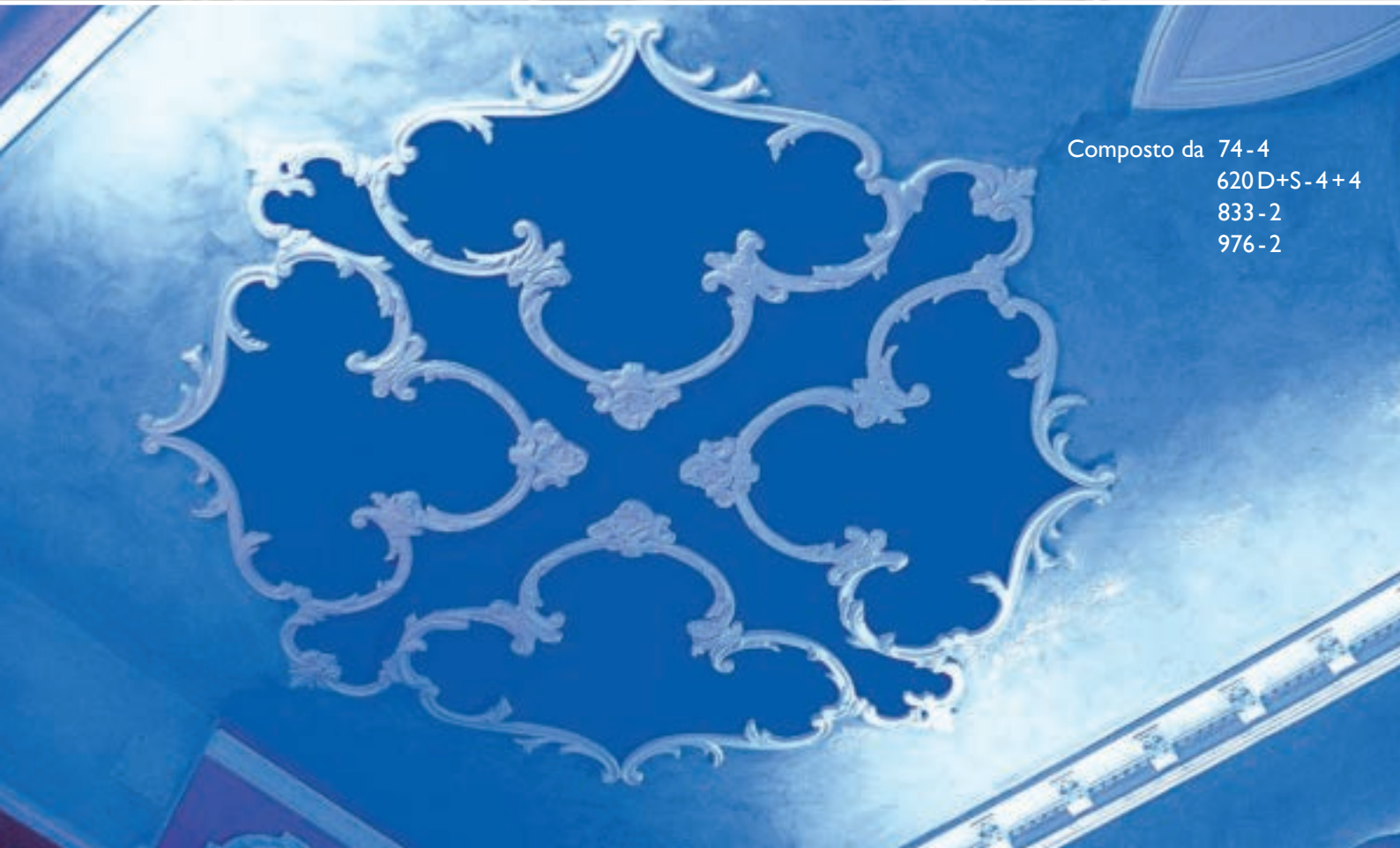

Composto da 74 - 4
620 D+S - 4 + 4
833 - 2
976 - 2



I cassettonati

Lacunar ceiling

Villa Fano del Poggio - Cassano (Ba)

Cassettonati

LACUNAR CEILING

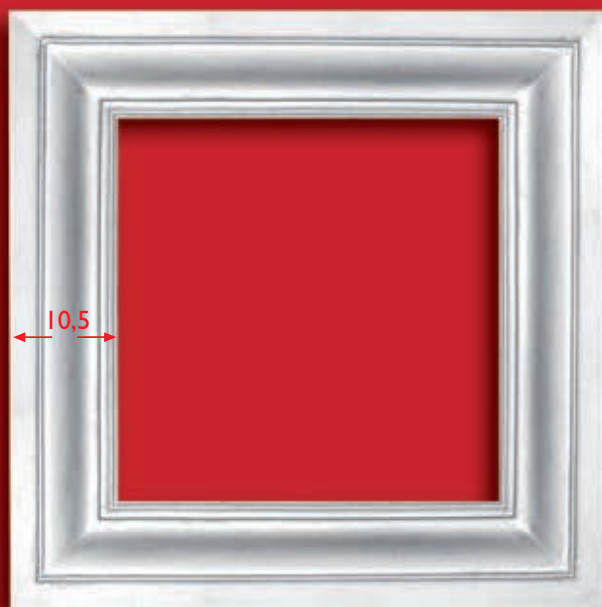

Art. **F 135** 58,5x58,5 p 6,5
NEW



Art. **F 136** 60x60 p 5
NEW

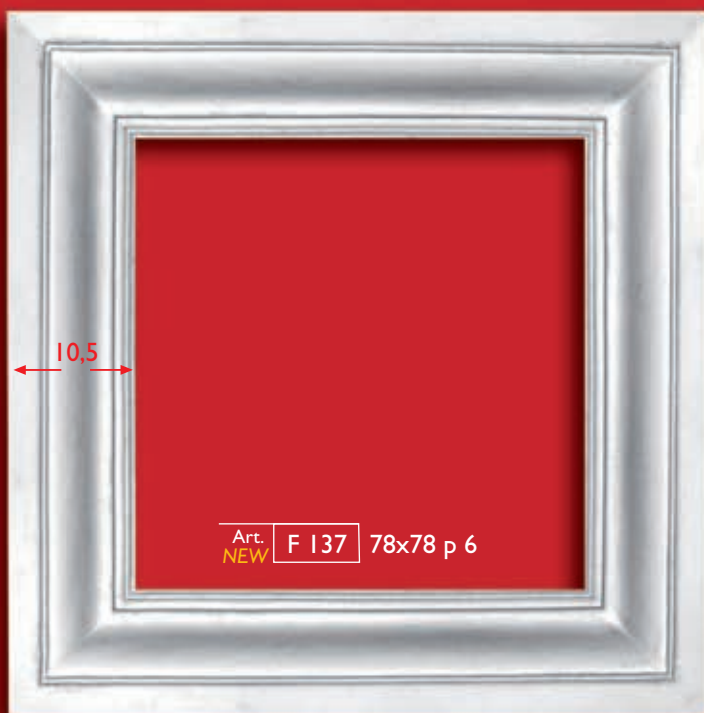

Art. **F 137** 78x78 p 6
NEW



Art. **F 138** 33x33
NEW



Art. **F 139** 35x35
NEW



Art. **F 140** Ø 16
NEW



Art. **F 141** Ø 13,5
NEW



Art. **F 142** Ø 9
NEW

Cassettonati

LACUNAR CEILING

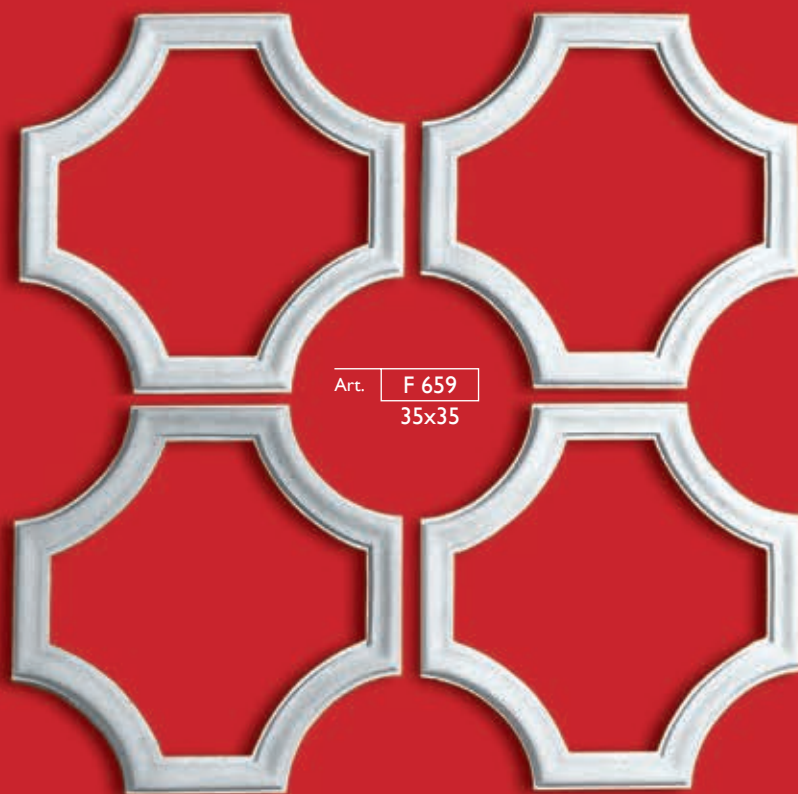

Art. **F 659**
35x35

Coprigancio
Art. **R 567**
Ø 16



Art. **626**
Ø 13,5



Art. **R 561**
Ø 13,5

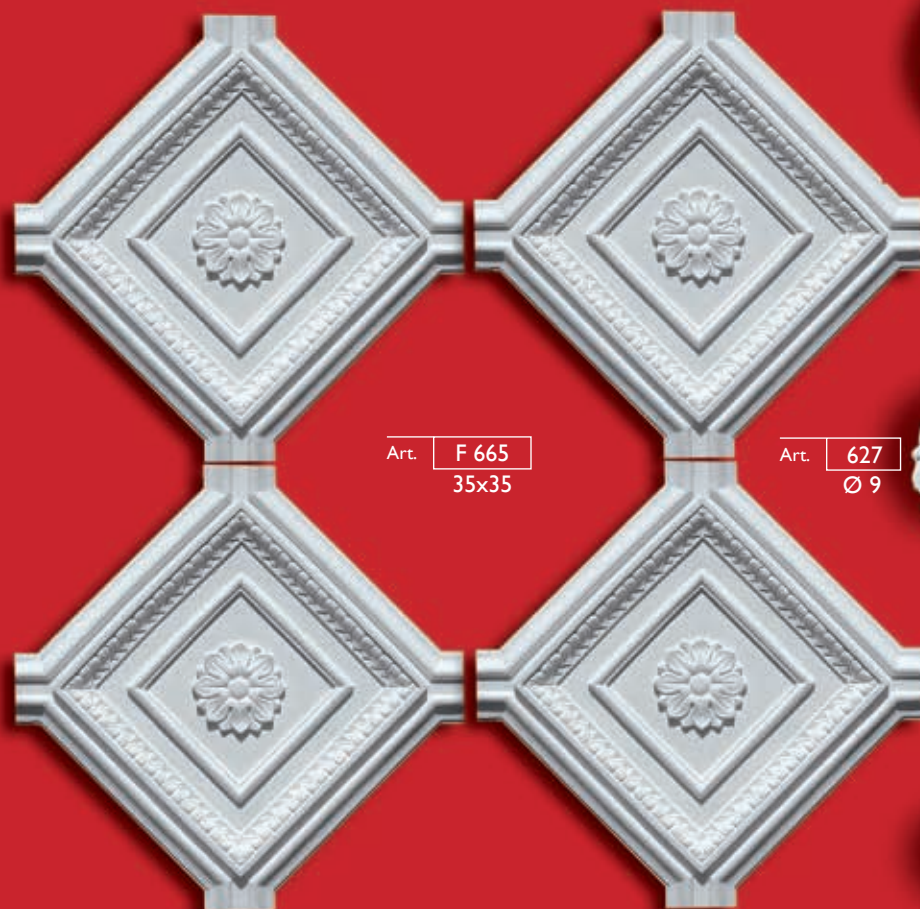

Art. **F 665**
35x35

Art. **627**
Ø 9



Coprigancio
Art. **R 566**
Ø 11

Art. **1083**
Ø 10,5



Art. **143**
NEW
Ø 9



Art. **628**
Ø 8,5



Art. **629**
Ø 5,5



Art. **1091**
Ø 5

L.V. STUCCHI

*Manufatti
in gesso*

PLASTER MANUFACTURED



I Rosoni

The ceiling rosettes

New Lions - Molfetta (Ba)

Rosoni

CEILING ROSETTES



Art. R 500
49x29



Art. R 502
82x66



Art. R 501
95x78



Art. R 503
49x29

Rosoni

CEILING ROSETTES



Rosoni

CEILING ROSETTES



Rosoni

CEILING ROSETTES



Art. **R 514**
69X40



Art. **R 513**
Ø 37



Art. **R 516**
Ø 40



Art. **R 515**
70X51

Rosoni

CEILING ROSETTES



Art. R 518
58X38



Art. R 517
59X41



Art. R 520
62X41



Art. R 519
64X44

Rosoni

CEILING ROSETTES



Art. R 522
Ø 38



Art. R 521
Ø 49



Art. R 524
Ø 42



Art. R 523
Ø 37

Rosoni

CEILING ROSETTES



Art. R 526
Ø 50



Art. R 525
Ø 48



Art. R 527
Ø 33



Art. R 529
Ø 41

Art. R 528
Ø 44

Rosoni

CEILING ROSETTES



Art. R 531
51X39



Art. R 530
Ø 52



Art. R 532
58X40



Art. R 533
Ø 55



Rosoni

CEILING ROSETTES



Art. R 535
Ø 34



Art. R 790
Ø 65



Art. R 537
Ø 49



Art. R 536
Ø 35

Rosoni

CEILING ROSETTES



Art. R 539
Ø 40



Art. R 538
Ø 45



Art. R 540
Ø 39



Art. R 542
Ø 44

Art. R 541
Ø 42

Rosoni

CEILING ROSETTES



Art. R 544
Ø 42



Art. R 543
Ø 45



Art. R 546
Ø 51



Art. R 545
Ø 47

Rosoni

CEILING ROSETTES



Art. R 548
Ø 22



Art. R 549
30X19



Art. R 551
Ø 32



Art. R 547
Ø 56



Art. R 550
34X20

Rosoni

CEILING ROSETTES



Art. R 554
Ø 38



Art. R 552
Ø 30



Art. R 553
Ø 24



Art. R 556
42,5X32,5



Art. R 555
Ø 40



Art. R 558
Ø 38



Art. R 557
Ø 44

Rosoni

CEILING ROSETTES



Art. R 563
Ø 54



Art. R 560
Ø 42



Art. R 565
Ø 39

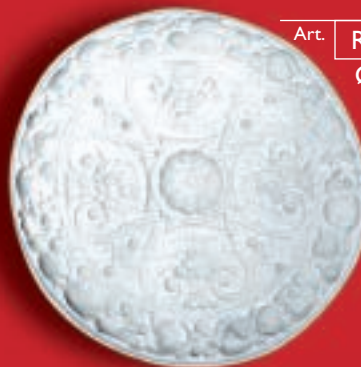

Art. R 562
Ø 37



Art. R 564
42X24



NEW
Art. R 144
Ø 22



Art. R 663
45x23



Art. R 559
Ø 30

Rosoni

CEILING ROSETTES



Rosoni a scomparsa
Embossed-effect ceiling rosettes



Art. R 988
Ø 95



Art. R 989
Ø 67



Art. R 990
Ø 69



Rosone a scomparsa
Embossed-effect ceiling rosette



Art. R 991
Ø 65

Art. R 992
87x64



Art. R 993
Ø 79

Rosoni

CEILING ROSETTES



Art. R 994
Ø 79



Art. R 995
Ø 69



Art. R 996
Ø 68



Art. R 997
Ø 53



Art. R 998
Ø 52

Rosoni

CEILING ROSETTES



Art. R 999
Ø 49



Art. R 1000
Ø 48,5



Art. R 1001
48x41



Art. R 1002
Ø 46



Art. R 1003
Ø 42



Rosoni

CEILING ROSETTES



Art. R 1004
Ø 40



Art. R 1005
Ø 38,5



Art. R 1006
Ø 38



Art. R 1007
Ø 39



Art. R 1008
Ø 34,5

Rosoni

CEILING ROSETTES



NEW
Art. R 145
59x44



NEW
Art. R 145D
59x44



NEW
Art. R 146
Ø 65



NEW
Art. R 146D
Ø 65



NEW
Art. R 147
51x40,5



NEW
Art. R 147D
51x40,5

Rosoni

CEILING ROSETTES



Art. R 510 D
77x64



Art. R 503 D
49x29



NEW
Art. R 148 D
Ø 41



Art. R 997 D
Ø 53



Art. R 531 D
51x39



Art. R 521 D
Ø 49

Rosoni

CEILING ROSETTES



Art. R 996D
Ø 68



Art. R 507D
Ø 61



Art. R 993D
Ø 79



Art. R 998D
Ø 52



Art. R 1001D
48x41

Rosoni

CEILING ROSETTES



Art. R 992D
87x64



Art. R 790D
Ø 65



Art. R 994D
Ø 79

Rosoni

CEILING ROSETTES



L.V. STUCCHI

*Manufatti
in gesso*

PLASTER MANUFACTURED

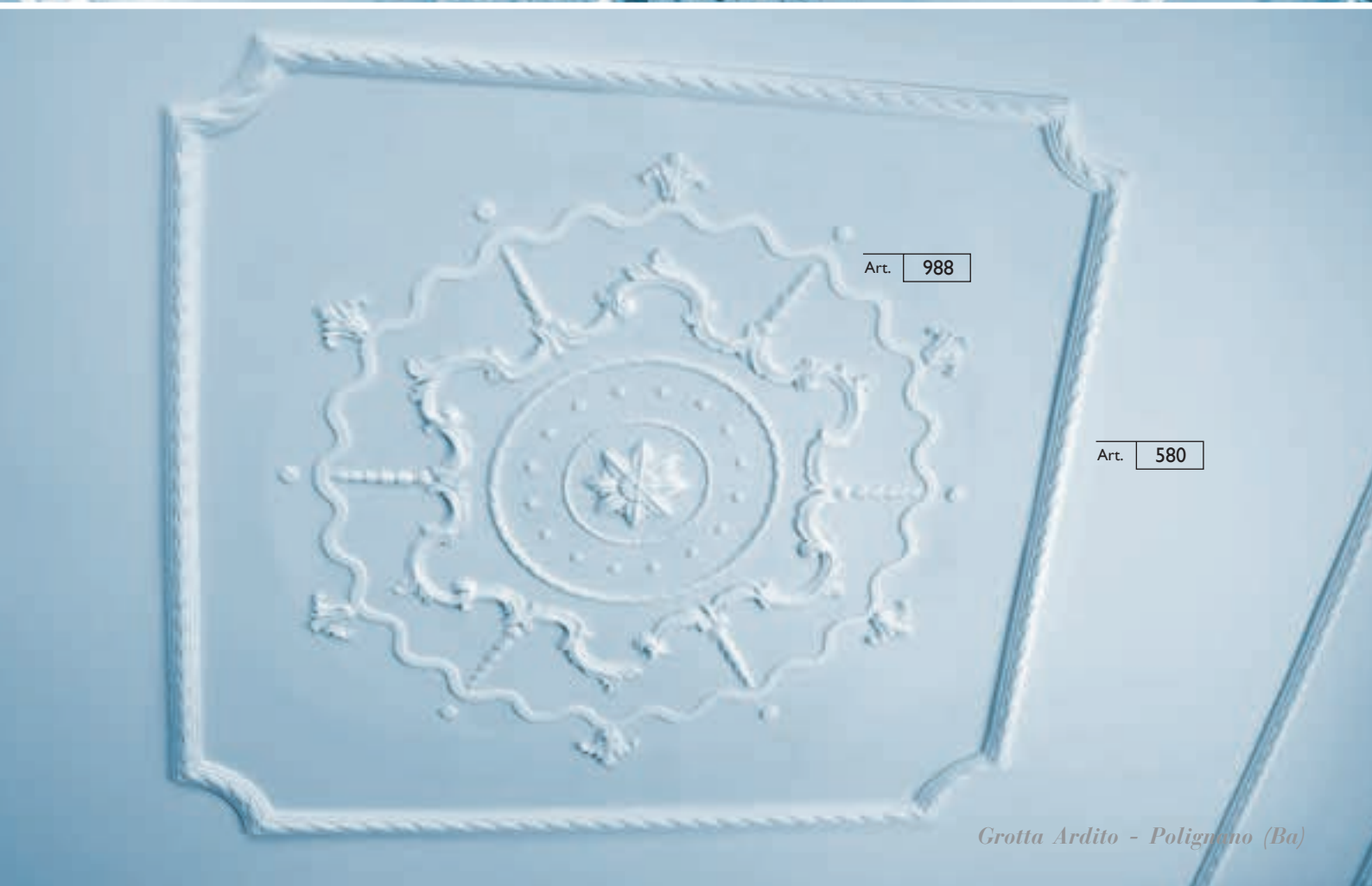

L.V. STUCCHI

*Manufatti
in gesso*

PLASTER MANUFACTURED



I Sovrapporta

The overdoors

New Lions - Molfetta (Ba)

Sovrapporta

OVERDOORS



Art. SP 709 h 31 b 112

Art. SP 353
h 9,5

Art. SP 246 h 9,5

Art. SP 246
h 200

Art. SP 334 h 28 b 112

Art. SP 335 h 40 b 88,5

Art. SP 247 h 25 b 9,5

Sovrapporta

OVERDOORS



Art. SP 241 h 25 b 110,5 p 8,5



Art. SP 243
h 9,5



Art. SP 242 h 19,5 b 122



Art. SP 346 15,5x11,5



Art. SP 347 s
31x11

Art. SP 347 d
31x11

Art. SP 348 15,5x11,5



Art. SP 349
44x11,5



Art. SP 244
9,5x200



Art. SP 350 73x11,5



Art. SP 351 33x13,5

Art. SP 245
9,5x25



Art. SP 352 23,5x13

Sovrapporta

OVERDOORS



Art. SP 1009
130x31

Art. SP 1009 s
18x19

Art. SP 1009 d
18x19



Art. SP 1010
146x42



Art. SP 1011
120x42



Art. SP 1012
127x38



Sovrapporta

OVERDOORS



Sovrapporta

OVERDOORS



NEW

Art. SP 250 h18 l18 p12

NEW

Art. SP 251 h18 l150 p9

NEW

Art. SP 252 h18 l18 p12



NEW

Art. SP 253 17,2x15

184,5

NEW

Art. SP 255 h56 l167,5 p15

NEW

Art. SP 254
h 2sml

17,2

NEW

Art. SP 256 h43 l159 p9

NEW

Art. SP 257 98,8x31



I Caminetti
The fireplaces



Caminietti

FIREPLACES





I Bassorilievi

The bas-reliefs

Bassorilievi

BAS-RELIEFS

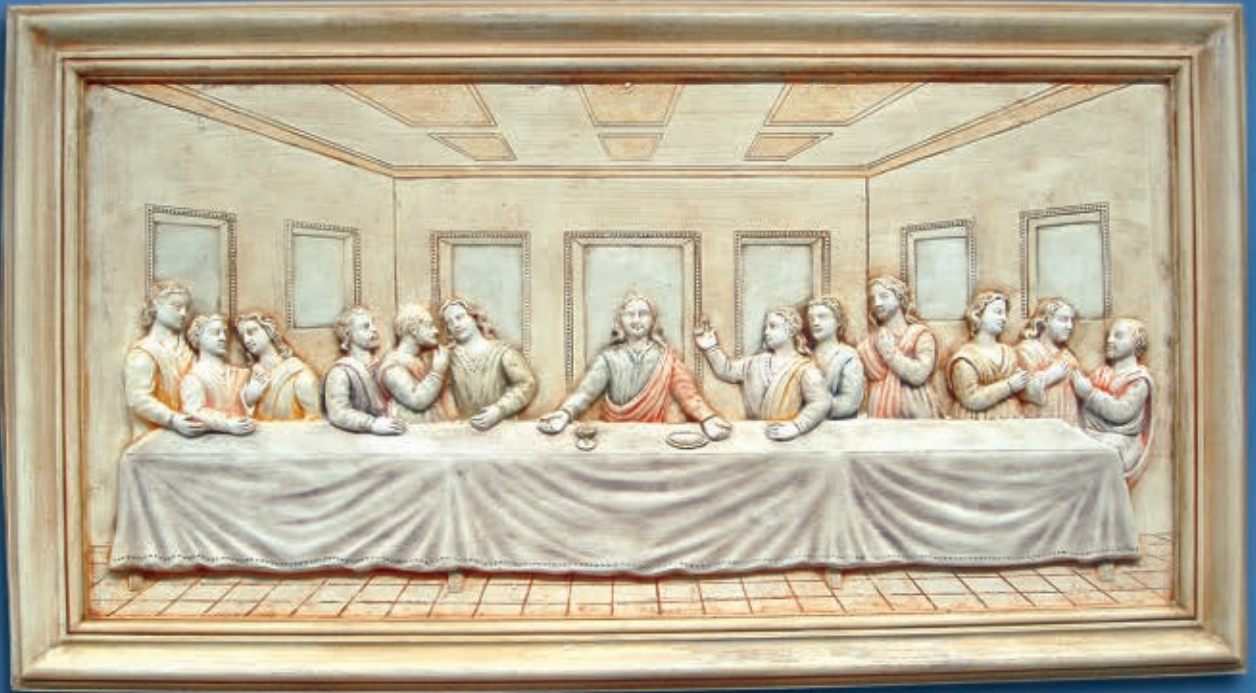

Art. B 1129
122x70



NEW
Art. B 261
120x62

Bassorilievi

BAS-RELIEFS



NEW
Art. B 262D
60x60 d85

NEW
Art. B 263D
60x60 d85



NEW
Art. B 262
60x60 d85



NEW
Art. B 263
60x60 d85

Bassorilievi

BAS-RELIEFS



Art. B 309 D
67x58



Art. B 308 D
118x34



Art. B 356 D
117x52



Bassorilievi

BAS-RELIEFS



Art. B 837 D
69x40



Art. B 838 D
90x59



Art. B 839 D
110x59



Bassorilievi

BAS-RELIEFS



Art. B 854 D
100x69



Art. B 855 D
80x66



Art. B 718 D
80x66



Bassorilievi

BAS-RELIEFS



Art. B 835 D
101x68



Art. B 836 D
90,5x68



Bassorilievi

BAS-RELIEFS



Art. B 840 D
30,5x20,5



Art. B 841 D
30x20



Art. B 842 D
30x20



Art. B 846 D
16x20



Art. B 843 D
30x20

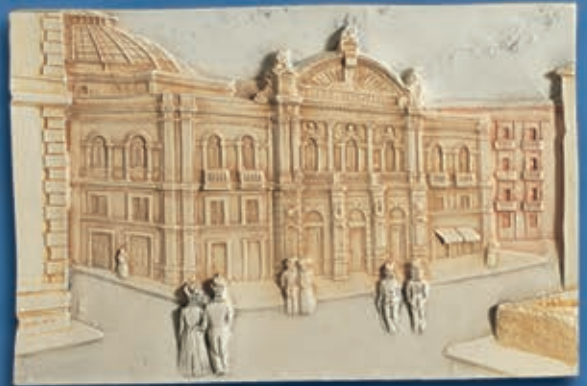

Art. B 844 D
30x20



Art. B 845 D
23,5x17,5



Bassorilievi

BAS-RELIEFS



Art. B 1013D
19x74



Art. B 1014D
82x79



Bassorilievi

BAS-RELIEFS



Art. B 851 D



Art. B 852 D
39x28



Art. B 853 D



Art. B 717 D
70x50



NEW
Art. B 856
39x28



Art. B 847 D
Ø 18



Art. B 848 D
Ø 18



Art. B 849 D
Ø 18



Art. B 850 D
Ø 18

Bassorilievi

BAS-RELIEFS



Art. B 1015D
116x32



Art. B 1016D
79x68



Art. B 1017D
h 13



Art. B 1018D
h 13

Art. B 1019D
h 13

Art. B 1021D
39x48



Art. B 1020D
39x48



Bassorilievi

BAS-RELIEFS



Art. B 1022D
27x37



Art. B 1023D
82x42



Art. B 1024D
27x37



Art. B 1025D
58x50



Art. B 1026D
33,5x78



Art. B 1027D
72x46



Bassorilievi

BAS-RELIEFS



Art. **B 1028D**
52x72



Art. **B 1029D**
40x31



Art. **B 1030D**
40x31



Art. **B 1033D**
28x53



Art. **B 1034D**
34x51



Art. **B 1035D**
32x44,5

Bassorilievi

BAS-RELIEFS



Art. B 1036D
75x42



Art. B 1037D
26x36



Art. B 1038D
39x64



Art. B 1039D
34x56



Art. B 1040D
35x57

Art. B 1041D
H 28



Art. B 1042D
H 28



Art. B 1043D
11x17



Art. B 1044D
H 32



Art. B 1045D
H 32



Bassorilievi

BAS-RELIEFS



Art. B 1046D
31x64



Art. B 1047D
26x16,5



Art. B 1048D
36x16



Art. B 1049D
21,5x17



Art. B 1050D
37x28



Art. B 1051D
32x26



Art. B 1053D
42x57



Art. B 1052D
33x27



Bassorilievi

BAS-RELIEFS



Art. B 1054D
131x25



Art. B 1055D
41x80



Art. B 1056D
26x51



Art. B 1057D
15,5x28



Art. B 1058D
20x8



Art. B 1060D
H 14



Art. B 1059D
15x24,5



Art. B 723D
H 13



Esempio di composizione con articoli 1054 e 1056

Bassorilievi

BAS-RELIEFS



Art. B 713D
10x21



Art. B 724
10,5



Art. B 713
10x21



Art. B 722D
10x8



Art. B 657D
15



Art. B 658D
14



Art. B 661D
15,5x21



Art. B 300D
22,5x23,5

L.V. STUCCHI

*Manufatti
in gesso*

PLASTER MANUFACTURED



I Pannelli

The panels



Pannelli

PANELS



NEW
Art. P 264
105x46,5



Catino Carlo

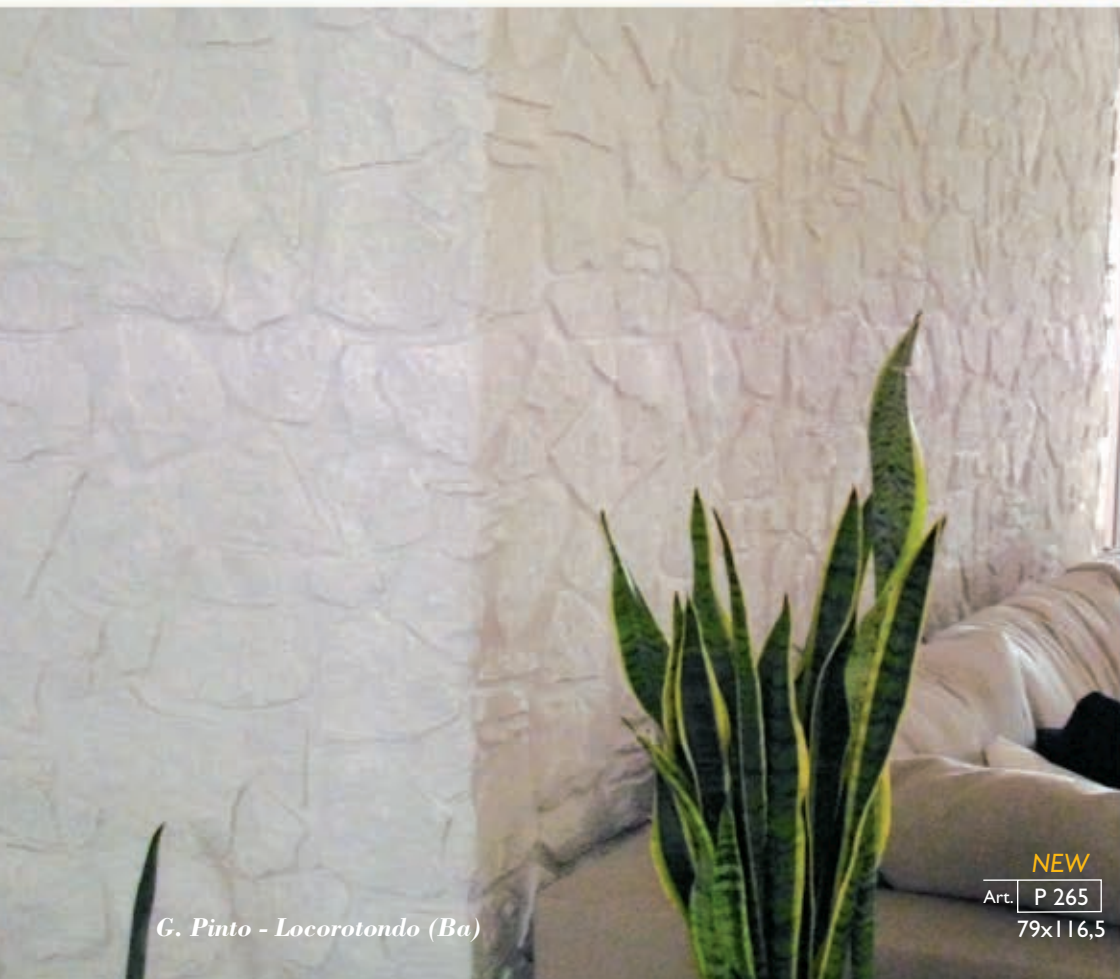

G. Pinto - Locorotondo (Ba)

NEW
Art. P 265
79x116,5



Pannelli

PANELS



NEW
Art. P 266
93x51

S. Fato - Valenzano (Ba)



NEW
Art. P 267
104x50

Pannelli

PANELS



NEW
Art. P 268
87x47,5



NEW
Art. P 269
46x26

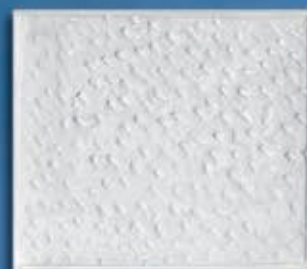
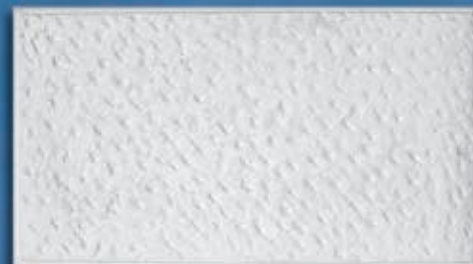

NEW
Art. P 270
30x26



Art. P 341
20x33

E sdi montaggio art. 341.



E sdi montaggio art. 269 - 270.

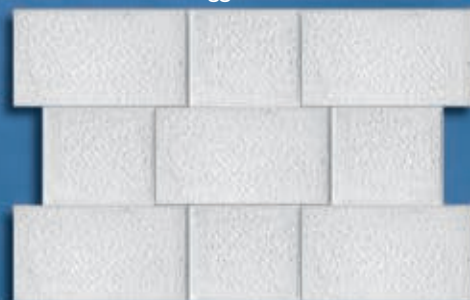

Gli articoli 264 - 265 - 266 - 267 - 268
possono essere curvati su ordinazione.



L.V. STUCCHI

*Manufatti
in gesso*
PLASTER MANUFACTURED



Le Boiserie

Boiserie



Art. Bo 708
89x60



Architetto De Filippo - Modugno



NEW
Art. Bo 271
60x60



Art. Bo 1063

Art. Bo 1064
H 150



Boiserie



Art. Bo 1065
60x60



Art. Bo 1066
34,5x60

Art. Bo 1067
30x60

Art. Bo 1068
200x30

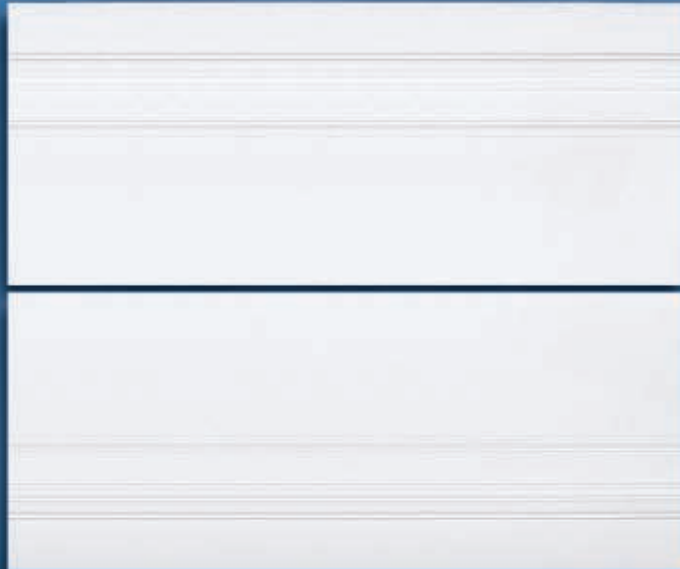

Chiavi per archi / Keys for arch

Art. Bo 1072



Art. Bo 1073



Art. Bo 1074



Tozzetti



Art. T 1075
15x15



Art. T 1076
12,5x12,5



Art. T 1077
12,5x12,5



Art. T 1078
12x12



Art. T 1079
11,5x11,5



Art. T 1080
11x11



Art. T 1081
10x10



Art. T 1082
10x10



Art. T 834
10,5x10,5



Art. T 1084
11x10



Art. T 1085
10,5x9



Art. T 1086
8x8



Art. T 1087
7x7



Art. T 1088
7x7



Art. T 1089
7x7



Art. T 1090
7x7



Art. T 78
NEW 8x8



Art. 965



Art. 970



Art. 949



Art. 969



Art. 964



Art. 968



Esempi di abbinamenti / Examples of combinations



Gli Applique

The light-holder

Appliche

LIGHT-HOLDER



Art. **D 1092**
b48 h32 p21



Art. **A 1093**
b33 h16 p14



Art. **A 1094**
b56 h14 p23



Art. **A 1095**
b26 h9 p13,5



Art. **A 569**
b33 h23,5 p12



Art. **A 568**
b40 h24 p17

Art. **A 570**
b25 h25 p12



Art. **A 571**
b32 h22 p17



Appliche

LIGHT-HOLDER



Art. **A 1096**
b33 h44 p18,5



Art. **A 1097**
b34 h16 p18



Art. **A 1098**
b40,5 h20 p22



Art. **A 1099**
b39 h19 p16,5



Art. **A 1100**
b56 h13 p23



Art. **A 1101**
b20x20 h15



Ad angolo
For corner

Appliche

LIGHT-HOLDER



Art. | A 301
| b34 h19,5 p19



Art. | A 345
| b30 h 11,5 p15



Art. | A 354
| b40 h12 p17



Art. | A 303
| b30 h10 p10



Art. | A 302
| b33,5 h15,5 p16,5



Art. | A 355
| b25,5 h12 p17



Art. | A 169a
| b26 h26 p22

Ad angolo
For corner



Art. | A 169
| b28 h26 p13

Art. | A 336
| b74,5 h10 p20,5

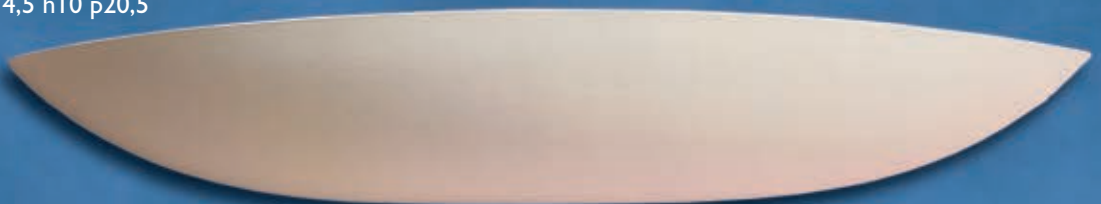

Applique

LIGHT-HOLDER



Art. | A 857
b35 h15,5 p12,5



Art. | A 858
b30 h14,5 p15



Art. | A 859
b33,5 h17 p17



Art. | A 860
b34,5 h20 p16



Art. | A 714 a
b22x22 h22 p22



Art. | A 714
b42 h22 p17,5



Art. | A 664
b20 h32 p15
da comodino
bedside



Art. | A 715
b36,5 h12 p18



Appliche

LIGHT-HOLDER



Art. | A 272
NEW | 36x36 h 46,5



Art. | A 273
NEW | 45 h 12,5 p 17,5



Art. | A 274
NEW | 20x20 h 36



Art. | A 275
NEW | 52x40

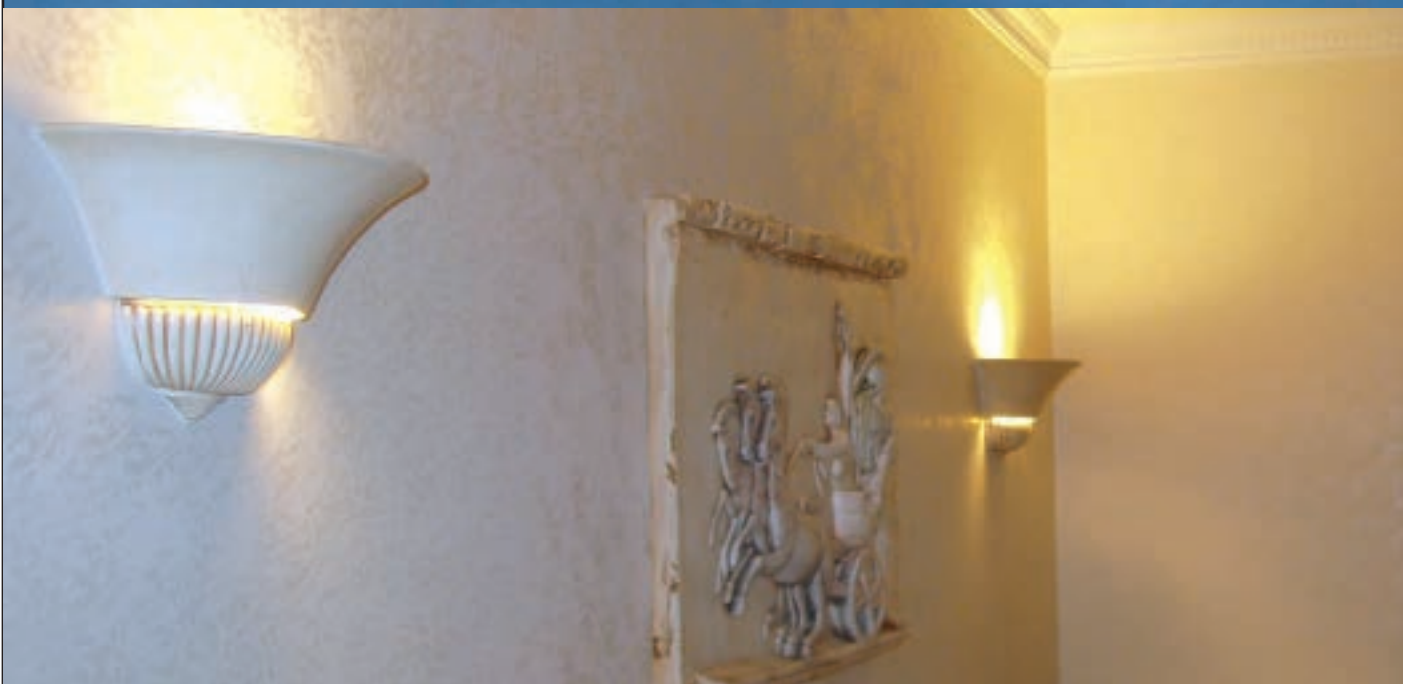



Le mensole

The corbels

New Lions - Molfetta (Ba)

Mensole

CORBELS



Art. **M 1102**
b23 h82 p12



Art. **M 1103D**
b30 h52 p21



Art. **M 1104D**
b48 h32 p21



Per angolo
Art. **M 1106**
18 h27x18

Art. **M 1105**
b34 h26 p16



Art. **M 1108D**
b32 h33 p16



Art. **M 1109**
b17 h44,5 p20



Art. **M 1107**
b18 h30,5 p14



Art. **M 1110**
b12 h25 p14



Art. **M 1111**
b5,5 h6,5



Art. **M 1112**
b8 h12,4



Mensole

CORBELS



Art. | M 668
b24 h29 p16



Art. | M 21
b22 h 28 p10



Art. | M 864
b18 h27,5 p13,5



Art. | M 863
b21,5 h26 p11,5



Art. | M 865
b20,5 h26 p10,5



Art. | M 319
b13 h30,5 p9,5



Art. | M 13
b15,5 h28 p11,5



Art. | M 862
b19,5 h23 p8,5



Art. | M 861
b12,5 h17 p5,8



Art. | M 667
b9 h23 p10



Art. | M 320
b12,5 h17 p7



Art. | M 15
b15 h15,5 p7



Art. | M 14
b10 h16,5 p8,5



Art. | M 666
b11,5 h10,5 p11,5



Mensole

CORBELS



Art. | M 276D
NEW | b33 h115 p29



Art. | M 277
NEW | b28 h50 p23



Art. | M 278
NEW | b11,5 h45



Art. | M 279
NEW | b18 h33,5 p21



Le Lesene *The pilasters*

Lesene

PILASTERS



Art. | L 339
| b37,5 h18



NEW
Art. | L 280



Art. | L 34



Art. | L 340
| b47 h18

Art. | L 322
| b54 h30



NEW
Art. | L 281



Art. | L 30

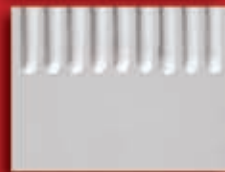

Art. | L 326
| b43 h10

Art. | L 868
| b50,5 h 24 p15,5



Art. | L 27



Art. | L 869
| b34 h24 p7



Lesene

PILASTERS



Art. L 323
b34 h22



NEW
Art. L 283
h 30



Art. L 23
h150

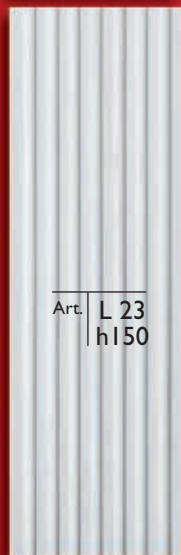

Art. L 327
b30,5 h11,5



Art. L 324
b28 h22



NEW
Art. L 284
h 30



Art. L 19
h150



Art. L 328
b26,5 h11,5



Art. L 282
b34 h22



NEW
Art. L 284
h 30



Art. L 19
h150



Art. L 328
b26,5 h11,5



Art. L 1115
b44 h14,5



Art. L 1116
20 h150



NEW
Art. L 285
h 15,5



Art. L 1117
b26 h15,5



Art. C 1123



Battiscopa
Skirting



Art. C 1124



Base per lesena
Base for pilasters



Art. C 1125

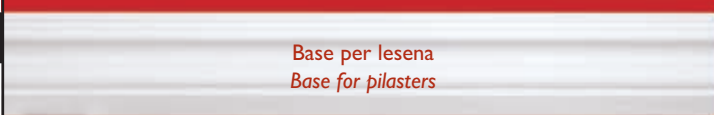

Base per lesena
Base for pilasters



Art. L 1126
24x19,5



Componibile con L23
Fitted with L23

Art. L 1127
21x4,5



Componibili con L16
Fitted with L16















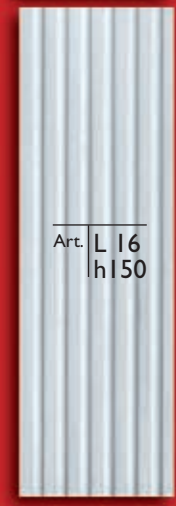

Art. L 1128
21x10

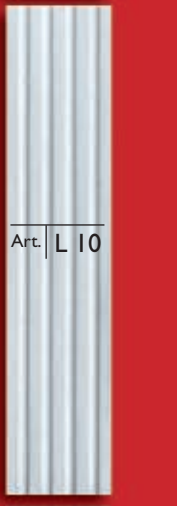

Lesene

PILASTERS



<p>Art. L 325 b25 h20</p>  <p>NEW Art. L 286 h 30</p>  <p>Art. L 16 h150</p>  <p>Art. L 329 b23,5 h11,5</p>	<p>Art. L 325 bis b24,5 h20</p>  <p>NEW Art. L 286 h 30</p>  <p>Art. L 16 h150</p>  <p>Art. L 329 b23,5 h11,5</p>	<p>NEW Art. L 287 b19,5 h10</p>  <p>NEW Art. L 288 h 30</p>  <p>NEW Art. L 12 h150</p>  <p>Art. L 289 NEW b19,5 h12</p>	<p>NEW Art. L 290 b12 h12</p>  <p>NEW Art. L 12 h150</p>  <p>NEW Art. L 291 b12 h12</p>  <p>Art. L 292 NEW b12 h15</p>	<p>Art. L 320 b12,5 h17</p>  <p>NEW Art. L 293 h30</p>  <p>Art. L 10</p>  <p>Art. L 872 b17 h11,5</p>	<p>Art. L 866 b15,5 h12</p>  <p>Art. L 870 b 10</p>  <p>Art. L 867 b16 h17</p>
--	--	---	--	--	---



Lesene

PILASTERS



Art. L 1113
38x9



Art. L 1114
30xh150



Art. T 1085
10,5x9

Art. L 298
NEW b71 h31

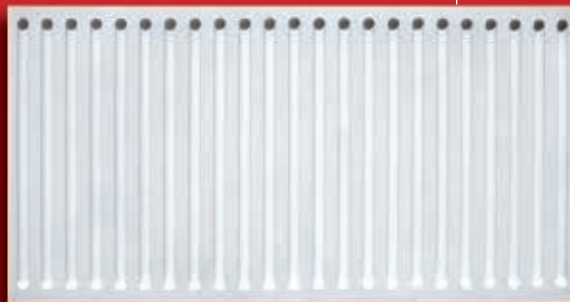

Art. L 1118
15x6



NEW
Art. L 294
h30

Art. L 1119
b9 h150

Art. L 1120
h 19



Per angoli
e spigoli

Art. L 1121
5x5
h150

Art. L 1122
h 20,5

NEW
Art. L 295
h 19



Per angoli

NEW
Art. L 296
6x6
h150

Art. L 297
NEW h 20,5

Esempi di applicazioni
Examples of applications



Art. L 296

Art. L 1121



Esempi di applicazioni / Examples of applications Art. L 298



Le Colonne

The columns

Colonna

Colonne

COLUMNS



Art. | C 5 Ø21
b34,5 h29



Art. | B2 Ø21
b33 h18

Art. | S 306
h77



Art. | C6 Ø21
b26,5 h16

Art. | CR Ø21

Art. | B2 Ø21
b33 h18

Art. | S 307
h58



Art. | C4 Ø26
b43 h17

Art. | CR Ø26

Art. | B2 Ø26
b37 h18

Art. | S 337
h33



Art. | C1 Ø13
b24,5 h17

Art. | CR Ø13

Art. | B2 Ø13
b25 h18



Art. | T 344 H42

Colonne

COLUMNS



Art. | C 4 Ø26
b43 h17

Art. | C 9 Ø16
* b27 h12

Art. | S 338
h54

Art. | BC 8 Ø21
b32xh6

Art. | BC 8 Ø10
b20 h6

Art. | C 8 Ø21
b31 h4,5

Art. | C 8 Ø10
b15 h4,5

Art. | CL Ø26

Art. | CL Ø21

Art. | CL Ø16

Art. | CL Ø10

Art. | B2 Ø26
b37 h18

Art. | B2 Ø21
b33 h18

Art. | B2 Ø16
b29 h18

Art. | B2 Ø10
b22 h18

Colonna

Colonne

COLUMNS



Art. | C9 Ø21
* | b32 h12



Art. | C9 Ø16
* | b27 h12

Art. | CC Ø21-26
| h 200

Art. | CC Ø16-21
| h 150

Art. | C5 Ø21
| b34,5 h29

Art. | B2 Ø26
| b37 h18

Art. | B2 Ø21
| b33 h18

Art. | CB Ø21
| h 200

Art. | B2 Ø21
| b33 h18

Colonne

Colonne

COLUMNS



Art. | C 3 Ø16
b24,5 h24



Art. | CL Ø16

Art. | B2 Ø16
b29 h18

Art. | C 7 Ø16
b34x27,5 h15



Art. | CR Ø16

Art. | B2 Ø16
b29 h18

Art. | C 2 Ø10
b19 h17



Art. | CL Ø10

Art. | B2 Ø10
b22 h18

Art. | C 2 Ø10
b19 h17



Art. | CR Ø10

Art. | B2 Ø10
b22 h18





Colonne

COLUMNS



Art. | S 306D



Art. | CR Ø21

Art. | C 6 Ø21

Art. | B2 Ø21



Art. | S 337 D



Art. | T 344 H42 D

Colonne

COLUMNS



Art. **C 10 Ø 16**
b29 h25,5 d36

Art. **CR Ø 16**
h 200

Art. **B2 Ø 16**
b29 h18



Art. **C 11 Ø 21**
b39 h30,5 d51

Art. **CR Ø 21**
h 200

Art. **B2 Ø 21**
b33 h18

Colonne

COLUMNS



NEW

Art. C 12 Ø 26
b44 h34

Art. CR Ø 26
h 200



Art. S 307D
h 58

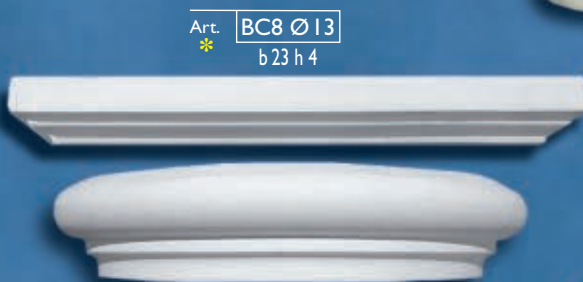

Art. BC8 Ø 13
* b23 h4

Art. C8 Ø 13
* b18 h7

Art. B2 Ø 26
b37 h19



Art. S 338D
h 54



Novità 2021

Cornici lineari

LINEAR FRAMES

Rosoni

CEILING ROSETTES

Lesene

PILASTERS

Bassorilievi

BAS-RELIEFS

Applique

LIGHT-HOLDER

Rivestimenti

COATINGS

Cartongesso

DRYWALL

Cornici lineari

LINEAR FRAMES



Art. 1170



Art. 1169

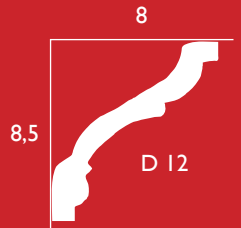

Art. 1167

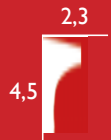

Art. 1166



Art. 1165



Art. 1164

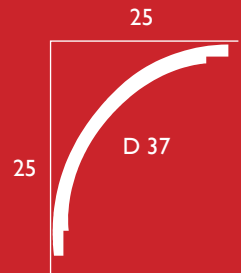
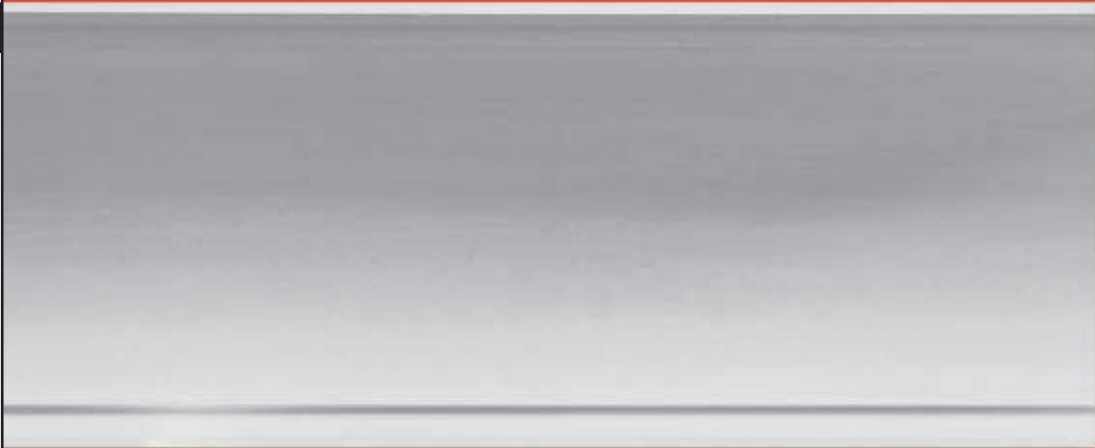

Art. 1163

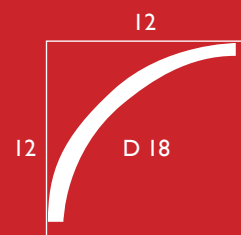
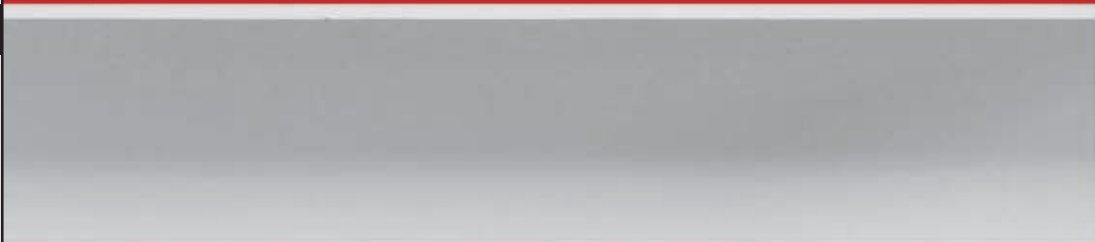

Cornici lineari

LINEAR FRAMES



Art. 1179

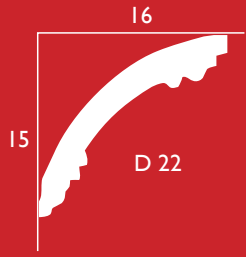

Art. 1178

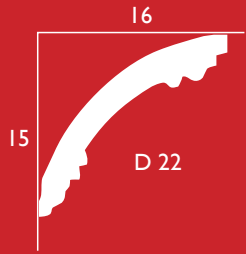

Art. 1177

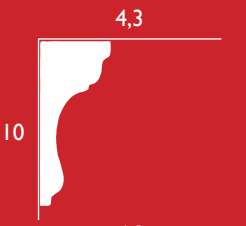

Art. 1176



Art. 1174



Art. 1173

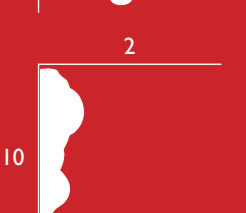

Art. 1172



Art. 1171



Cornici lineari

LINEAR FRAMES



Art. 1185

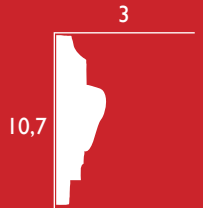

Art. 1184

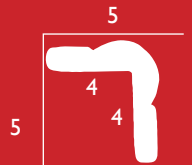

Art. 1183

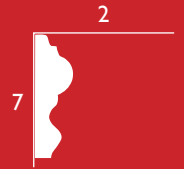

Art. 1182

Battiscopa

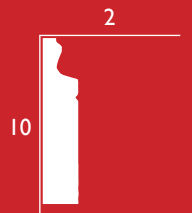
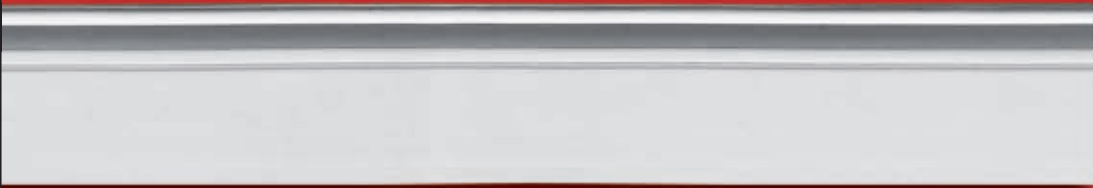

Art. 1181

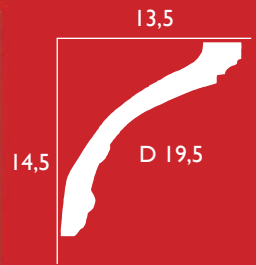

Art. 1180

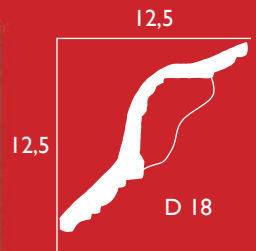

Art. 694 bis

Battiscopa

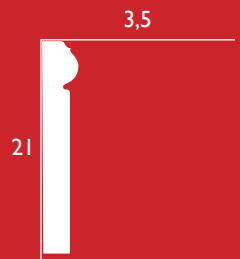
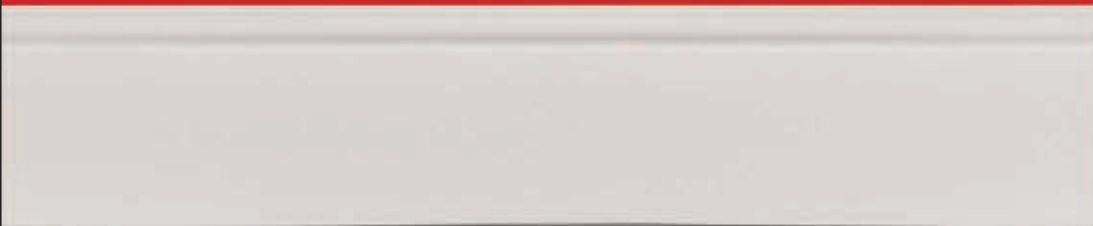

Rosoni

CEILING ROSETTES



Art. 1136
Ø51



Art. 1137
Ø36



Art. 1141
Ø30



Art. 1138
Ø71



Art. 1139
57x41,5



Art. 1142
49x25



Art. 1140
Ø45

Lesene

PILASTERS



Art. | 1145
b12,5 h6,5



Art. | 1148
b10 h1,20



Art. | 1149
b10x h11



Art. | 1148
b10 h1,20



Art. | 1147
b14,3 h4



Art. | 1148
b10 h1,20



Art. | 1146
b11 h19



Art. | 1154
b35,5 h123



Art. | 1154
b35,5 h123



Art. | 1160
b10 h15



Art. | 1161
b10 h0,50



Art. | 1161
b10 h0,50



Art. | 1162
b10 h20,5

Bassorilievi

BAS-RELIEFS



Art. 1132
28x46



Art. 1135
18,5x38,4



Art. 1133
31,5x22



Art. 1134
18,5x38,4



Art. 1186
Ø55



Art. 1188
93,5x12



Art. 1152
19x22

Art. 1151
41x15

Mensole e altro

CORBELS AND MORE



Art. 1175a
29,5x29,5



Art. 1175
11,5x4,5



Art. 1175a
29,5x29,5



Art. 1159
b21 h54 p19



Art. 1157
b47 h20,5 p18,8



Art. 1175
11,5x4,5



Art. 1175
11,5x4,5

Art. 1156
b17 h32 p14



Art. 1158
b23 h42

Art. 1150
b15,5 h10,7



Art. 1175b
12,3x16,4



Art. 1175b
12,3x16,4

Art. 1155
10x12,5



Applique

LIGHT-HOLDER



Art. 1244
b27 h17,5 p12



Art. 1247
b51 h9,5 p12,5



Rivestimenti



COATINGS



Art. 446
70x70x2

Art. 447
138x50x2,5

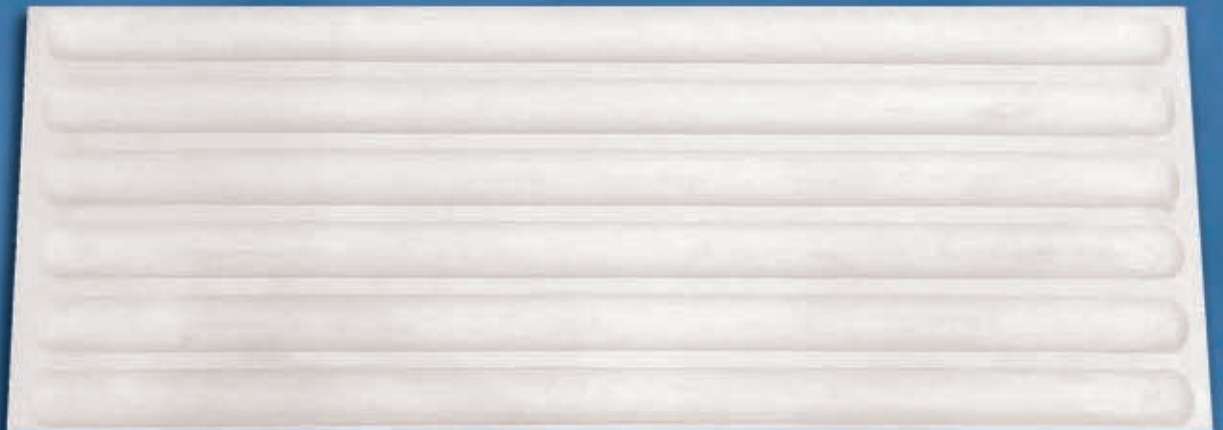



LINEA CARTONGESSO

per interni e per esterni

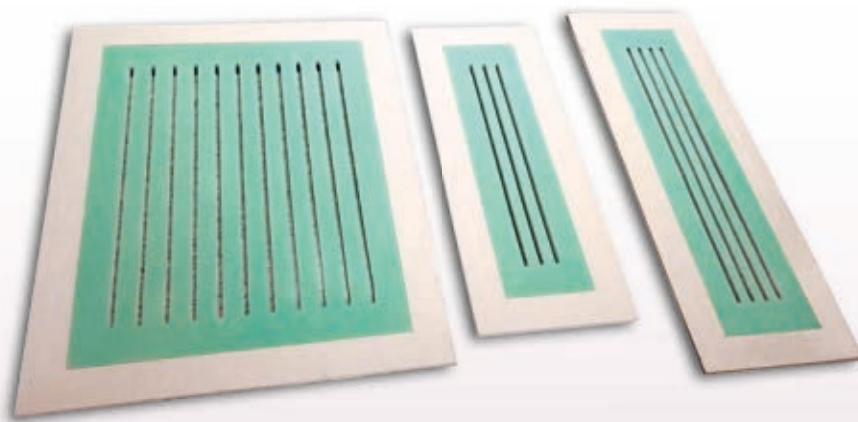

**Botole su misura
di nostra produzione**

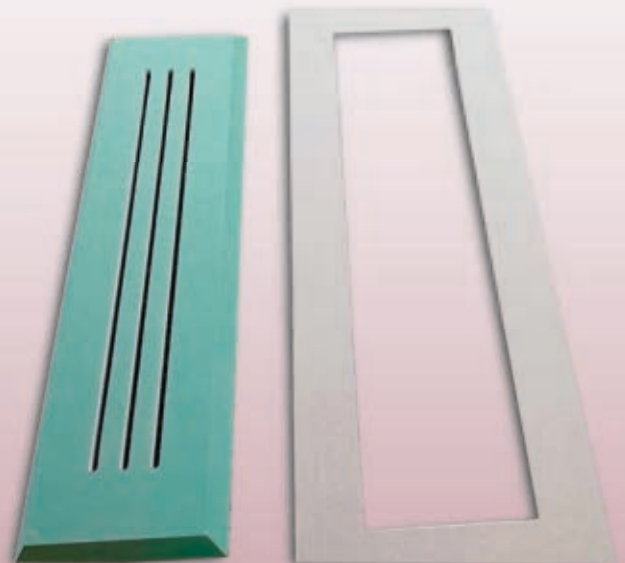

L.V. STUCCHI

*Manufatti
in gesso*

PLASTER MANUFACTURED



ART. 3000

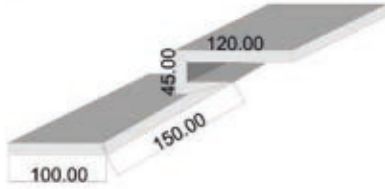

ART. 3006



ART. 3001

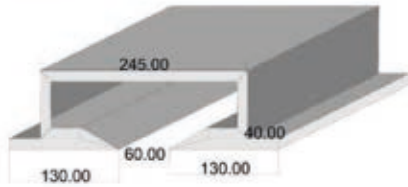

ART. 3007

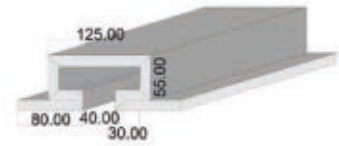

ART. 3002

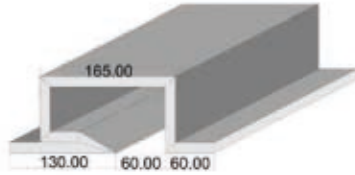

ART. 3008

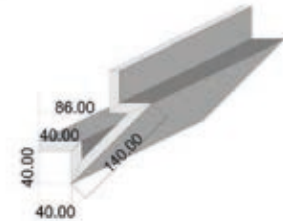

ART. 3003

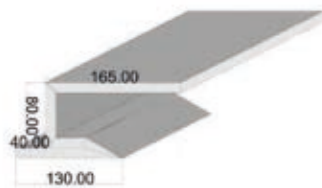

ART. 3009

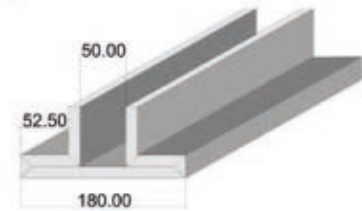

ART. 3004

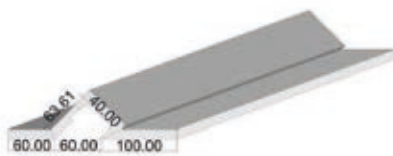

ART. 3010

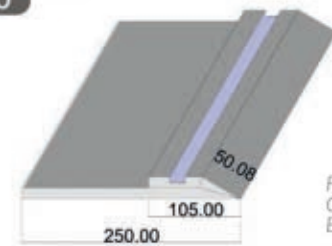

FORNITO
CON DISSIPATORE
E OPALINO

ART. 3005

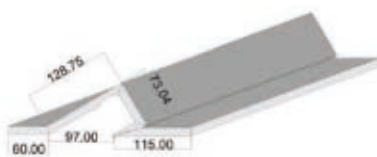

ART. 3011

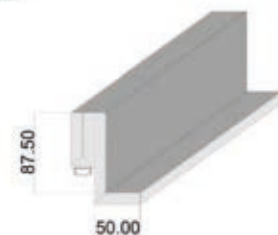

L.V. STUCCHI

*Manufatti
in gesso*



PLASTER MANUFACTURED

ART. 3012

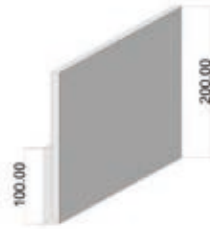

ART. 3018

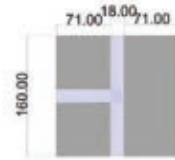

FORNITO
CON DISSIPATORE
E OPALINO

ART. 3013

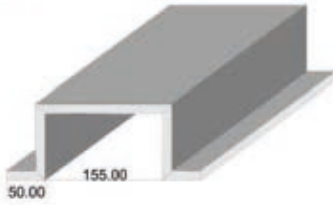

ART. 3019



FORNITO
CON DISSIPATORE
E OPALINO

ART. 3014

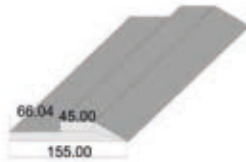

ART. 3020

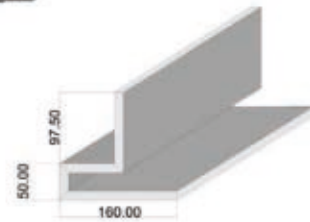

ART. 3015

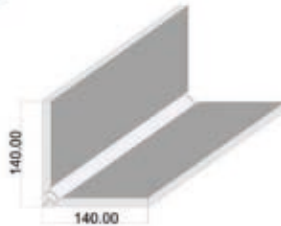

FORNITO
CON DISSIPATORE
E OPALINO

ART. 3021

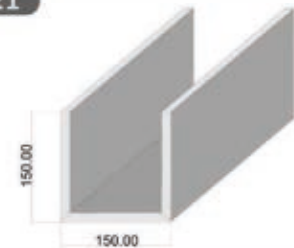

ART. 3016

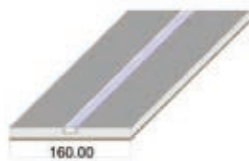

FORNITO
CON DISSIPATORE
E OPALINO

ART. 3022

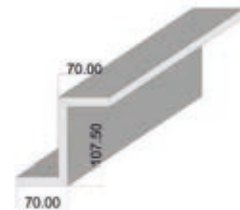

ART. 3017

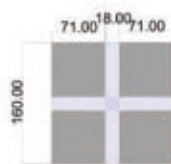

FORNITO
CON DISSIPATORE
E OPALINO

ART. 3023

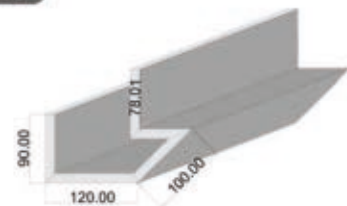



ART. 3024

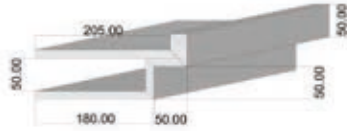

ART. 3025

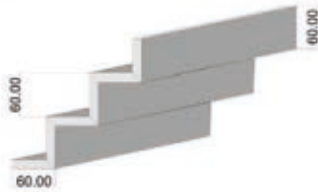

ART. 3026

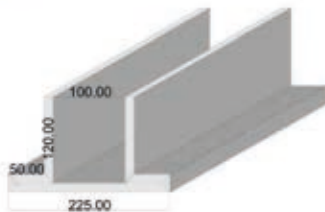

ART. 3027

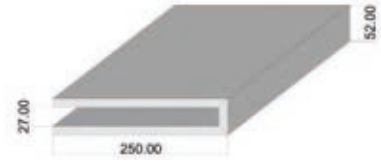

ART. 3028

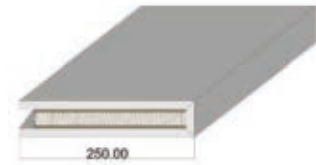

MENSOLA
CON MDF
E NIDO D'APE

ART. 3029

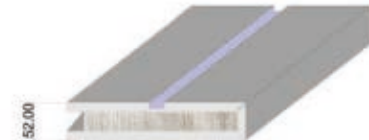

MENSOLA
CON TAGLIO
PER PROFILO LED
FORNITO
CON DISSIPATORE
E OPALINO

ART. 3030

Disponibili in magazzino

art.	modello
3030	20x20 in alluminio
	30x30 in alluminio
	40x40 in alluminio
	50x50 in alluminio
	60x60 in alluminio
	40x30 in alluminio
	50x40 in alluminio
	60x20 in alluminio
	60x40 in alluminio

su richiesta qualsiasi misura

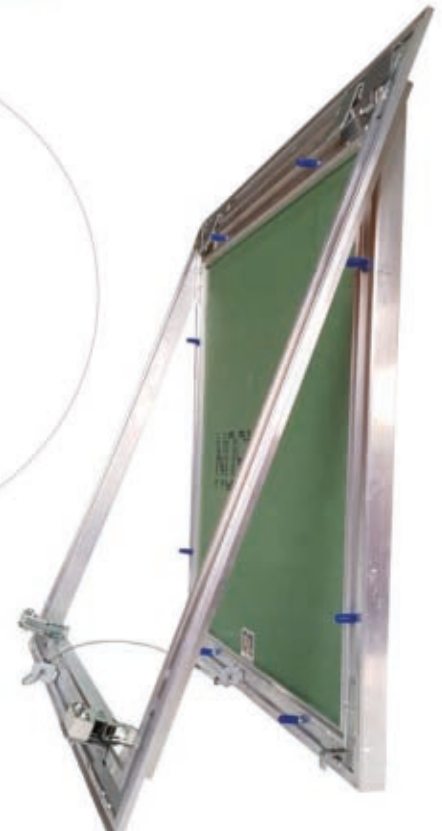



Novità 2020

Ante in legno su misura
anche personalizzate





Realizzazione di una cupola ovale ellittica / *Creation of an elliptical oval dome*

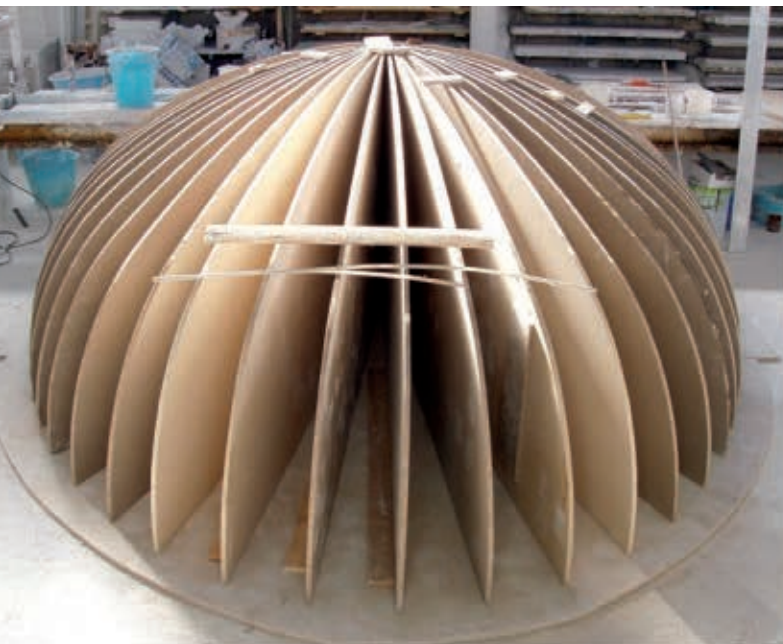

L.V. STUCCHI

*Manufatti
in gesso*



PLASTER MANUFACTURED



Cortenova - Casamassima (Ba)

Lavorazioni

su misura

CUSTOMIZED MANUFACTURING



La nostra azienda è specializzata anche nella realizzazione di manufatti ex-novo ripresi da disegni o foto.

Prima fase della lavorazione: creazione del modello in argilla.

Our company is specialized in the production of manufactured goods from scratch taken from drawings or photos.

First phase of the process: creating the model in clay.



Seconda fase della lavorazione: realizzazione della forma in gomma.
Second phase of the process: creation of the mould of rubber.

Teatro comunale
Umbero I di Bitonto



Lavorazioni

su misura CUSTOMIZED MANUFACTURING



Terza fase della lavorazione: la sformatura. / *Third phase of production and mold release.*



In opera. / *Completed work.*

Teatro comunale Umbero I di Bitonto





L.V. STUCCHI

*Manufatti
in gesso*



PLASTER MANUFACTURED

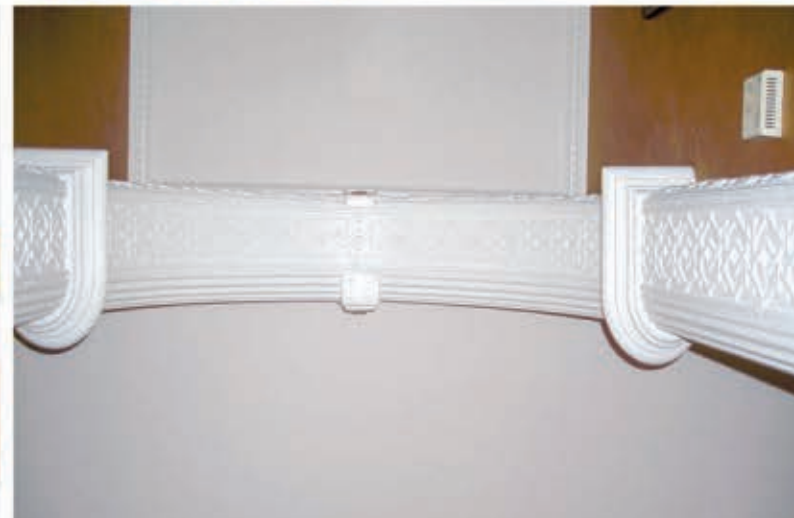



Art. 976



Esempi di composizioni con i fregi
Examples of compositions with freizes

Art. 975
Art. 979
Art. 980
Art. 981
Art. 628
Art. 346



Art. 621
Art. 976
Art. 630
Art. 628



Art. 621
Art. 981
Art. 346
Art. 628



RESTAURI

In questa sezione del catalogo riportiamo alcune esempi di restauri da noi effettuati, sia su cantieri totalmente distrutti, dove quindi bisognava creare gli stucchi basandosi solo su vecchie foto o disegni, come il Teatro Umberto I (Bitonto - Ba), che su cantieri dove gli stucchi erano in parte distrutti e quindi si trattava di riprenderli e riportarli dove mancavano come il Teatro Margherita e il Teatro Petruzzelli (Bari).

PER ESTERNO

Per l'esterno abbiamo studiato un nuovo composto idrorepellente a base di gesso Alfa (**GSP gesso speciale per esterno**) che garantisce una elevata resistenza agli agenti atmosferici e che con l'applicazione di pitture specifiche per esterno può resistere anche agli agenti atmosferici più aggressivi quali la pioggia battente, dando al manufatto una resistenza pressoché illimitata paragonabile ad un manufatto realizzato in cemento, con un peso specifico inferiore di circa il 40% consente una maggiore rapidità e facilità di applicazione.

RESTORATIONS

In this section of the catalogue we illustrate a few examples of restorations of construction sites, some of which were completely destroyed, such as the Umberto the 1st theatre of Bitonto, where in order to create the stuccos, we utilized old photos or drawings specifically for the sites where the stuccos were partially destroyed. Then we them took these stuccos and returned them to their original place. Some examples are the Petruzzelli Theater and The Margherita Theater as well.

FOR EXTERIOR

*For the exterior we have studied a new water-repellent compound of plaster Alfa (**SEP special exterior plaster**) that provides high resistance to bad weather and that, with the application of specific paints for outside, can withstand the most aggressive bad weather such as driving rain, giving the product a nearly unlimited strength comparable to a product made of cement, but with specific weight less than about 40% and which therefore enables higher quickness and easiness of application.*

Teatro Umberto I



L.V. STUCCHI

*Manufatti
in gesso*



PLASTER MANUFACTURED



Restauro eseguito
in gesso per esterno
e resina acrilica.

*Restaration made
with plaster for exterior
and with acrylic resins.*





L.V. STUCCHI

*Manufatti
in gesso*



PLASTER MANUFACTURED



L.V. STUCCHI

*Manufatti
in gesso*

PLASTER MANUFACTURED



Teatro Petruzzelli



L.V. STUCCHI

Manufatti
in gesso
PLASTER MANUFACTURED



New Lion - Molfetta (Ba)



L.V. STUCCHI

*Manufatti
in gesso*

PLASTER MANUFACTURED



Grotta Ardito - Polignano (Ba)



Composizioni

su misura

COMPOSITIONS MADE TO MEASURE

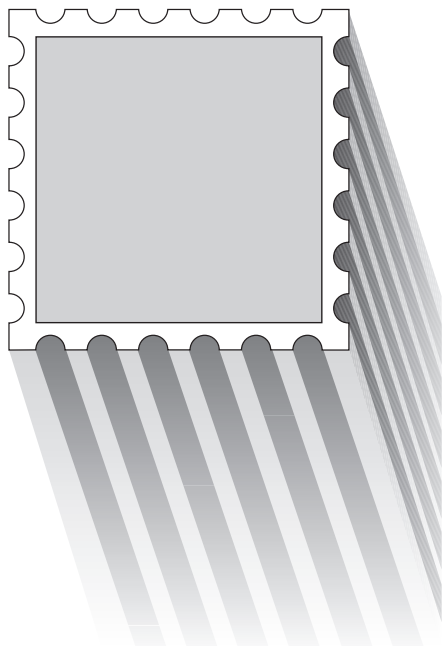

Lesene

Si eseguono lesene su misura per rivestimenti di pilastri di qualsiasi dimensione.

Pilaster

Pilaster are manufactured to measure for coating pillars of any size.

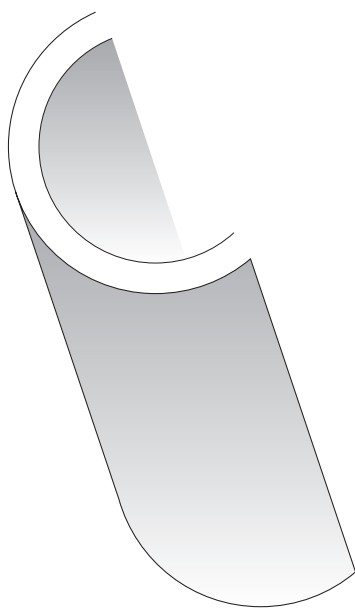

Semicolonne / Half columns

- Art. CL 877 ovale 64x79 (max rivest. per pilastro 50x50)
- Art. CL 878 ovale 52x38 (max rivest. per pilastro 33x30)
- Art. CL 883 Ø32
- Art. CL 884 Ø34
- Art. CL 885 Ø38
- Art. CL 886 Ø43
- Art. CL 887 Ø49
- Art. CL 888 Ø56
- Art. CL 889 Ø60
- Art. CL 890 Ø65
- Art. CL 891 Ø70
- Art. CL 896 Ø80
- Art. CL 897 Ø86
- Art. CL 879 Ø120 h100

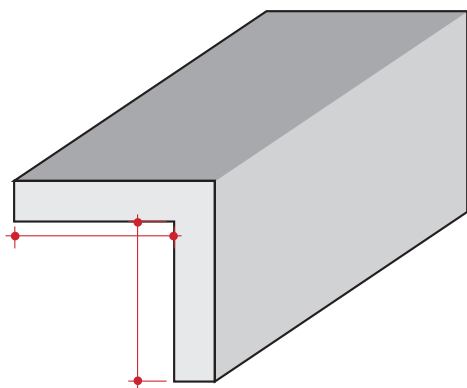

Canaletti / False ceiling channels

- Art. C 675 - 3x3
- Art. C 676 - 5x5
- Art. C 677 - 10x10

Le misure si riferiscono alla parte interna.
The dimensions refer to the inside.

Su ordinazione qualsiasi misura.
To order any size.

Manufatti in gesso

PLASTER MANUFACTURED



Oltre agli articoli illustrati nel catalogo, la nostra azienda realizza i seguenti articoli:
Rasostucco disponibile da kg. 1/5/20 ottimo per rasare e per l'applicazione degli stucchi alla parete;
Pannelli di gesso per controsoffitti di m. 1,50 x 0,67.

Realizziamo inoltre su richiesta qualsiasi opera o manufatto in cemento, gesso speciale per esterno e resina acrilica.

*In addition to the items shown in the catalog, our company manufactures the following products:
Smoothing stucco available in packages of 1/5/20kg, very good to smooth and for the application of stucco to the wall;
Plasterboard ceiling of m 1,50 x 0,67.*

We make moreover, any work or manufactured article on request, even made of cement, plaster for outside and acrylic resins.

Un sincero ringraziamento ai nostri affezionati clienti che, con le loro continue richieste, ci hanno portato alla ricerca di nuovi articoli, finalmente integrati in questo catalogo. Tra questi citiamo diversi in stile etnico tanto di moda in questo periodo.

A sincere thanks to our loyal customers who, with their constant demands, have led us to search for new products finally integrated in the catalog. These include various ethnic style articles, so fashionable in this period.



L.V. Stucchi rispetta l'ambiente usando solo vernici e resine acriliche.

L.V. Stucchi is environmentally friendly, using only acrylic paints and resins.

Le misure degli articoli riportate nel presente catalogo sono puramente indicative e non costituiscono impegno determinante per la ditta costruttrice, la quale si riserva il diritto di cambiare o apportare modifiche atte a migliorare il prodotto a suo insindacabile giudizio.

The sizes of the items in this catalogue are purely indicative and not binding for the manufacturer who reserves the right to change or improve the product at his own unquestionable judgement.



Parco dei Principi - Foggia



*Gesso per esterno
Parco dei Principi - Foggia*

Timbro del rivenditore / *Stamp of dealer*

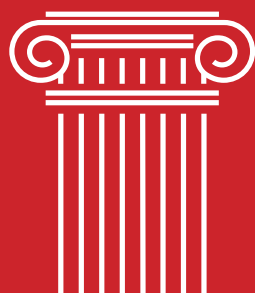

L.V. STUCCHI s.r.l.

manufatti in gesso / plaster manufactured

Strada Comunale per Capurso, s.n.
70010 Valenzano - Bari

Tel. 080.467.31.87 - WhatsApp 351.87.33.603

e-mail: info@lagioiavitosnc.it - info@lagioiastucchi.it

www.lagioiastucchi.it

